



INSTALLATION AND MAINTENANCE INSTRUCTIONS

G-SERIES GREASE DUCT

MODELS:

PSW - PIC

1G / 1GV / IPIC-1

2G / 2GV / IPIC-2

3G / 3GV / IPIC-3

4G / 4GV / IPIC-4

WARNING!!

A MAJOR CAUSE OF GREASE DUCT & CHIMNEY RELATED FIRES IS FAILURE TO MAINTAIN REQUIRED CLEARANCES (air spaces) TO COMBUSTIBLE MATERIALS. IT IS OF UTMOST IMPORTANCE THAT THE GREASE DUCT BE INSTALLED ONLY IN ACCORDANCE WITH THESE INSTRUCTIONS.



637N
FACTORY BUILT
GREASE DUCT

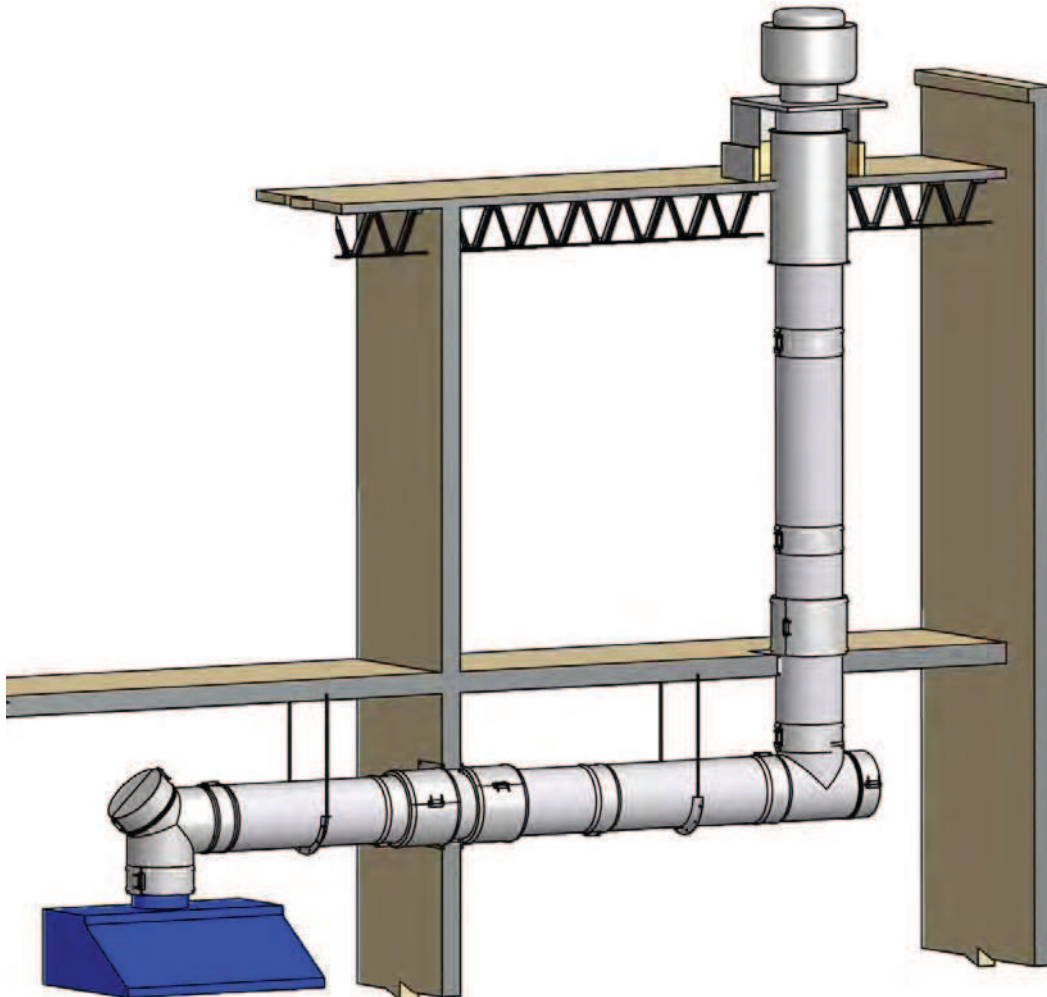

IMPORTANT: DO NOT INSTALL GREASE DUCT WITHOUT FIRST READING THESE INSTRUCTIONS VERY CAREFULLY.

Metal-Fab's Grease Duct Systems have been fully tested and are listed by Underwriters Laboratories, Inc. and Underwriters Laboratories of Canada. Grease Ducts installed per these instructions meet the requirements of NFPA 96.

This booklet contains complete information on details concerning dimensions, installation, clearances to combustibles, and use of non-combustible enclosures. For any additional construction information, refer to G-Series Design Manual.

METAL-FAB, INC. • P.O. BOX 1138, WICHITA, KANSAS 67201 • (316) 943-2351

TABLE OF CONTENTS

CODE COMPLIANCE	2
PRODUCT CERTIFICATION	3
PRODUCT INSPECTION	4
GENERAL INFORMATION	4
MIXING PARTS	4
CLEARANCES	4
JOINT ASSEMBLY	4
DUCT SLOPE	5
PART NUMBERS	5
PRODUCT WEIGHTS	5
THERMAL EXPANSION CALCULATIONS	5
SUPPORTS	6
PLATE AND WALL SUPPORTS	6
VARIABLE & ADJUSTABLE LENGTH SUPPORT	9
ELBOW SUPPORT	9
TEE SUPPORT	10
THROUGH FLOOR (FIRESTOP) SUPPORT	11
PENETRATIONS	11
THIMBLES	11
FIRESTOPS	13
GUYING REQUIREMENTS	15
COMPONENTS	16
STRAIGHT SECTIONS	16
FITTINGS - ELBOWS, WYES, TEES, & TRANSITIONS	18
SPRINKLER HEAD ACCESS PANEL (SHAP)	23
FAN ADAPTER PLATE (FAP)	23
FAN/CURB TERMINATION	23
MAINTENANCE	24
OPERATING PRECAUTIONS (WOOD OVENS)	24

NOTE: Dimensions in these instructions are in American standard (feet and inches), with Metric (mm) in parenthesis except where stated otherwise.

CODE COMPLIANCE

LISTINGS

Metal-Fab Models PSW, PIC, IPIC, and 1G , 1GV / 2G, 2GV / 3GV, 3G / 4G, 4GV are “listed” by Underwriters Laboratories (UL File No. MH 25506) and by Underwriters Laboratories of Canada (ULC File No. CMH1272) for Grease Duct applications when installed in accordance with these instructions and National Fire Protection Association standard “NFPA 96, Standard for Ventilation Control and Fire Protection of Commercial Cooking Operations.”

CLASSIFICATIONS

Model 4G / 4GV / IPIC-4 is “Classified” by Underwriters Laboratories in accordance with SBCCI Public Safety Testing and Evaluation Services, Inc. Evaluation Guide on Fire Resistance Construction (Flexible Duct Wrap Enclosure Systems), dated January 1, 1998 as an alternate to 3-Hr. fire rated shaft enclosure with a minimum zero clearance to combustibles (sizes 6” to 36” diameter). It is also classified under UL 2221 (Tests of Fire Resistive Duct Enclosure Assemblies) as an alternate to 2-Hr. fire resistive shaft enclosures with a minimum zero clearance to combustibles (sizes 6” to 36” diameter). Duct evaluated in accordance with the requirements for duct enclosure Condition A.

Model 3G / 3GV / IPIC-3 is classified under UL 2221 (Tests of Fire Resistive Duct Enclosure Assemblies) as an alternate to 2-Hr. fire resistive shaft enclosures with a minimum zero clearance to combustibles (sizes 6” to 36” diameter). Duct evaluated in accordance with the requirements for duct enclosure Condition A.

Model 2G / 2GV / IPIC-2 is also classified under UL 2221 (Tests of Fire Resistive Duct Enclosure Assemblies) as an alternate to 2-Hr. fire resistive shaft enclosures with a minimum 3” clearance to fully enclosed construction (sizes 6” to 18” diameter). Duct evaluated in accordance with the requirements for duct enclosure Condition B.

APPLICATION

Metal-Fab Model IPIC (G-Series) grease ducts are listed as grease duct for continuous temperature of 500°F and intermittent temperatures of 2000°F.

G-Series grease duct is ideally suited for use in commercial cooking installations for the removal of smoke and grease laden vapors. Grease duct system size and capacity information may be obtained from the “ASHRAE Handbook – Fundamentals” or from the “Air Pollution Engineering Manual” of the “US Environmental Protection Agency.”

For sizes 6” - 14” diameter, Models IPIC-2, IPIC-3 and IPIC-4 are listed as a chimney per UL103-HT. Where kitchen exhaust ducts are considered to be used as a flue, this listing can be applicable. For continuous flue temperatures that may exceed 600°F, P071 ceramic sealant shall be used.

PRODUCT CERTIFICATION

Metal-Fab G-Series grease ducts are tested and listed to UL 1978 and UL 2221 by nationally recognized laboratories. Per these listings, product labeling is required. Below is an example of product certification labels.

(W) CAT. NO.:

IPIC POSITIVE PRESSURE CHIMNEY SYSTEMS & G-SERIES GREASE DUCT SYSTEMS

UL LISTED 637N BUILDING HEATING APPLIANCE CHIMNEY PART, ALSO LISTED 1400°F (760°C) FACTORY BUILT CHIMNEY PART. RESIDENTIAL TYPE AND BUILDING HEATING APPLIANCE CHIMNEY PART. GREASE DUCT PART, FOR RESTAURANT COOKING APPLIANCE.

CHIMNEY SYSTEMS ARE LISTED IN ACCORDANCE WITH UL 103 TEST STANDARD. CHIMNEY SYSTEMS ARE TESTED TO BE CONNECTED TO OIL OR GAS FIRED EQUIPMENT PRODUCING FLUE GAS TEMPERATURES NOT EXCEEDING 1400°F (760°C).

CHIMNEY SYSTEMS ARE RATED FOR USE AT MAXIMUM 60 INCH WATER COLUMN INTERNAL PRESSURE, WHEN USED IN POSITIVE PRESSURE APPLICATIONS IN ACCORDANCE WITH METAL-FAB'S INSTALLATION INSTRUCTIONS.

CHIMNEY SYSTEMS ARE LISTED IN ACCORDANCE WITH UL103-HT TEST STANDARD. CHIMNEY SYSTEMS ARE TESTED TO BE CONNECTED TO SOLID FUEL, OIL OR GAS FIRED EQUIPMENT PRODUCING CONTINUOUS FLUE GAS TEMPERATURES NOT EXCEEDING 1000°F(538°C).

GREASE DUCT PART FOR RESTAURANT COOKING APPLIANCE ARE LISTED IN ACCORDANCE WITH UL1978 TEST STANDARD.

MINIMUM CLEARANCE (AIR SPACE) TO COMBUSTIBLE MATERIALS AND BUILDING INSULATION ARE LISTED BELOW.

MODEL	DUCT DIAMETER	CHIMNEY		GREASE DUCT
		UL103	TYPE-HT	
IPIC-3	3" (76mm) INSULATION			
	6"(152mm) thru 14"(356mm)	1"(25mm)	2"(50mm)	0"(0mm)
	16"(406mm) thru 34"(863mm)	1"(25mm)	N/A	0"(0mm)
	36"(914mm)	3"(76mm)	N/A	0"(0mm)
IPIC-4	4" (101mm) INSULATION			
	6"(152mm) thru 14"(356mm)	1"(25mm)	2"(50mm)	0"(0mm)
	16"(406mm) thru 34"(863mm)	1"(25mm)	N/A	0"(0mm)
	36"(914mm) thru 38"(965mm)	3"(76mm)	N/A	0"(0mm)
	40"(1016mm) thru 48"(1219mm)	3"(76mm)	N/A	1"(25mm)

CLASSIFIED UL 7N71 GREASE DUCT FOR USE IN GREASE DUCT ASSEMBLIES CLASSIFIED IN ACCORDANCE WITH UL2221 SEE UL FIRE RESISTANCE DIRECTORY.

FOR USE IN GREASE DUCT ASSEMBLY NO. G-1 CLASSIFIED AS AN ALTERNATE TO 2 HR. FIRE RESISTIVE RATED SHAFT ENCLOSURE SYSTEM WITH A MINIMUM ZERO CLEARANCE TO COMBUSTIBLES.

IPIC-3 AND IPIC-4 (SERIES 3G & 4G GREASE DUCT) ARE EVALUATED FOR USE AS A 2-HR. FIRE RATED, ZERO CLEARANCE GREASE DUCT SYSTEM PER **UL ER15388-01** FOR USE AS AN ALTERNATE TO 2-HR. FIRE RESISTANCE RATED SHAFT ENCLOSURE SYSTEM WITH A MINIMUM ZERO CLEARANCE TO COMBUSTIBLES.

SEE THROUGH-PENETRATION FIRESTOP SYSTEM NO. **C-AJ-7006** AND **W-L-7124** IN UNDERWRITERS LABORATORIES INC. FIRE RESISTANCE DIRECTORY, VOL. 2, FOR FIRE RATED INSTALLATIONS THAT REQUIRE PENETRATION OF RATED WALLS OR FLOOR/ CEILING.

CAUTION: RISK OF FIRE. DO NOT FULLY ENCLOSE WITH COMBUSTIBLE MATERIALS. INSTALL AND USE ONLY IN ACCORDANCE WITH METAL-FAB INC. INSTALLATION AND MAINTENANCE INSTRUCTIONS.

P3765-XX

METAL-FAB INC.
WICHITA, KS.

GREASE DUCT DIAMETER

MINIMUM CLEARANCE TO COMBUSTIBLES

ZERO CLEARANCE TO COMBUSTIBLES

WARNING: DO NOT FULLY ENCLOSE WITHIN COMBUSTIBLE CONSTRUCTION

RECOGNIZED AS ALTERNATE TO FIRE RATED ENCLOSURE

UL EVALUATION REPORTS

FIRE STOP INFORMATION

PRODUCT INSPECTION

Grease duct components are shipped on individually marked skids. Compare the labeled skids to the packing list to ensure all components of the grease duct system have been shipped. For missing components contact Metal-Fab CVP Customer Service Department at 800-835-2830.

FREIGHT DAMAGE

Each component should be checked for freight damage when it is unloaded at the site. For damaged components contact the shipping company as soon as possible to file a claim.

PROPER STORAGE

All grease duct components should be stored in a dry place until installed. Sealant shall be stored in location where it will not freeze.

GENERAL INFORMATION

MIXING PARTS

Mixing other manufacturer's grease duct components with a Metal-Fab grease duct system is not allowed unless listed for such use (consult Metal-Fab, Inc.) and will negate the duct listings and warranty.

CLEARANCES

G-Series grease duct is primarily intended for use in non-combustible surroundings. When installed in an open room where enclosure is not required, the G-Series grease duct may be located at clearance to combustibles in accordance with **TABLE 1**.

TABLE 1-GREASE DUCT CLEARANCES

DUCT MODEL	FLUE DIA.	COMBUSTIBLE	LIMITED COMBUSTIBLE	NON-COMBUSTIBLE
PSW	6"-48"	18" (457)	--	0"
PIC	6"-10"	5" (127)		
	12"	7" (178)		
	14"	9" (229)		
	16"	10" (254)	--	0"
	18"	12" (305)		
	20"	14" (356)		
	22"-48"	18" (457)		
IPIC-1	6"	2" (51)	2" (51)	
	8"-18"	3" (76)	3" (76)	
IPIC-1G	20"-32"	4" (102)	3" (76)	0"
IPIC-1GV	34"-42"	5" (127)	3" (76)	
	44"-48"	6" (151)	3" (76)	
IPIC-2	6"-18"	1" (25)	1" (25)	
	20"-32"	2" (51)	2" (51)	
IPIC-2G	34"-42"	3" (76)	3" (76)	0"
	44"-48"	4" (102)	3" (76)	
IPIC-3G	6"-36"	0"	0"	0"
IPIC-3GV	6"-36"	0"	0"	0"
IPIC-4G	6"-38"	0"	0"	0"
IPIC-4GV	40"-48"	1" (25)	1" (25)	0"

The above figures represent air space, in inches (mm), to unenclosed combustible surroundings.

IPIC-2 IPIC-2G IPIC-2GV	6"-18"	Minimum 3" (76) air space to combustibles when fully enclosed in combustible construction.
-------------------------------	--------	---

Buildings more than one story in height and in one-story buildings where the roof-ceiling assembly is required to have a fire resistance rating, the duct must be enclosed in a continuous enclosure from the lowest fire-rated ceiling or floor above the hood, through any concealed spaces, to or through the roof to maintain the integrity of the fire separations required by the applicable building code provisions. If the building is less than 4 stories in height, the enclosure shall have a fire resistance rating of not less than 1 hour. If the building is 4 stories or more in height, the enclosure shall have a fire resistance rating not less

than 2 hours. The clearance between the outside of a single wall duct and the inside of the rated enclosure must be a minimum of 6 inches or as required by local code. For IPIC Series Grease Duct, See **TABLE 1 - GREASE DUCT CLEARANCES**.

NOTE: Model IPIC-3G & IPIC-4G is equivalent to a 2-Hr. fire rated grease duct enclosure system and provides zero clearance to combustible construction and complies with NFPA 96, The International Mechanical Code and The Uniform Mechanical Code.

NOTE: Model IPIC-2G is equivalent to a 2-Hr. fire rated grease duct enclosure system when located within a fully enclosed space of combustible or limited combustible construction and maintaining a minimum 3" clearance to combustibles. Complies with NFPA 96, The International Mechanical Code and The Uniform Mechanical Code.

Combustible roofs or roof-ceiling assemblies may be penetrated using the Roof Support Assembly (RSA), Ventilated Thimble Assembly (VTA), or Fan Curb Termination (FCT). A Fan Adapter Plate (FAP) with a ventilated roof curb may also be used for penetration.

NOTE: Do not enclose with combustible materials.
(Exception: IPIC-2 - See Table 1)

JOINT ASSEMBLY

All grease ducts are to be liquid tight per NFPA 96. The following steps are to be used to ensure that this requirement is met.

STEP 1

Fill the channel of the flange band with P080 sealant and install below flange of first pipe section.

NOTE: Sealant is supplied by Metal-Fab and individual tubes are marked P080. See **TABLE 2** for number of tubes per joint.



NOTE: For UL103-HT type installations P071 ceramic sealant may be used; Consult manufacturer.

CAUTION: THE USE OF ANY OTHER SEALANT ON THE FLANGE SURFACE WILL NEGATE ALL LISTINGS OF THE PRODUCT AND IMPAIR THE SEALING EFFECTIVENESS.

TABLE 2-EXPECTED NUMBER OF TUBES PER JOINT

DUCT DIAMETER	NUMBER OF TUBES	DUCT DIAMETER	NUMBER OF TUBES
6"	0.20	28"	0.50
8"	0.20	30"	0.67
10"	0.20	32"	0.67
12"	0.25	34"	0.67
14"	0.25	36"	0.67
16"	0.25	38"	1.00
18"	0.33	40"	1.00
20"	0.33	42"	1.00
22"	0.33	44"	1.00
24"	0.50	46"	1.20
26"	0.50	48"	1.20

STEP 2

Apply a continuous bead of P080 sealant 1/4" wide to one of the flanges to be joined.



STEP 3

Join the two flanged ends of the duct section together and rotate slightly to ensure complete coverage of sealant on flanges.

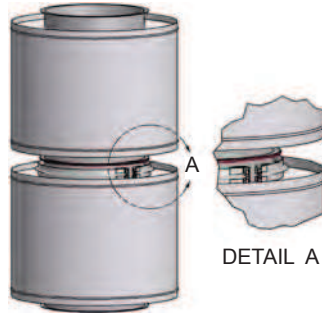

STEP 4

Install the flange band around the flanges making sure the flanges are located within the V-Clamp.

NOTE: Do not locate V-Clamp hardware at the bottom side of horizontal duct joints.

NOTE: Light tapping with a hammer all around the band while tightening the end clamp bolts helps align and pull flanges together.



INSULATION STRIPS (PROVIDED)

STEP 5

Install the supplied insulation strips between the sections to ensure that all air gaps are filled. Be sure that insulation is tightly packed and completely fills the void between flue and closure band when assembled.



STEP 6

Align casing band grooves over duct casing beads as shown. Secure the outer casing with the closure band. Joint installation is now complete.

NOTE: Seal the casing closure band with P077 sealant if exposed to weather.



DUCT SLOPE

Nationally recognized codes require horizontal ducts to slope at a minimum of 1/4 unit vertical in 12 units of horizontal toward the hood or grease reservoir. In addition, where horizontal ducts exceed 75 feet in length, the slope shall not be less than one unit vertical in 12 units horizontal. This general rule for duct slope is prescribed for grease ducts that are not listed and/or evaluated by an accredited third body testing agency. For factory-built grease ducts that are listed to UL1978 and have been further tested and/or analyzed to provide equivalent or better flow characteristics as compared to field-installed grease ducts, reduced duct slope is allowed per the factory-built grease duct listing.

For Metal-Fab factory built grease ducts listed to UL1978, install at a duct slope not less than 1/16 unit vertical slope in 12 units of horizontal toward the hood or toward the grease reservoir. Where Metal-Fab grease ducts listed to UL1978 exceed 75 feet in length, the slope shall not be less than 1/4 unit vertical slope in 12 units horizontal. This minimum slope is a result of tests and analysis performed by Underwriters Laboratories, where factory-built grease duct was compared to rectangular field-applied grease duct for performance of flow characteristics. Consult with AHJ for acceptance of this alternate method.

PART NUMBERS

These instructions identify grease duct model parts by name of part number in text and illustrations. Model definitions are as follows:

- PSW: Single Wall Duct
- PIC: Double Wall Duct with 1" Airspace
- IPIC: Insulated Double Wall Duct

Actual parts also carry a inner duct wall diameter prefix and a three digit "CTO" suffix which defines the materials of construction, such as 24IPIC30-461 for 24" diameter double wall duct section 30" long with type 304 stainless steel inner wall, type 316 stainless steel outer wall and a 1" insulation. (See **Table 3** or further explanations of CTO codes).

TABLE 3-GREASE DUCT CTO CODE

1 ST DIGIT (INNER WALL)	2 ND DIGIT (OUTER WALL)	3 RD DIGIT (INSULATION)
3 = 430 S.S. 4 = 304 S.S. 6 = 316 S.S.	A = Aluminized Steel 4 = 304 S.S. 6 = 316 S.S.	0 = 1" Air Space 1 = 1" Insulation 2 = 2" Insulation 3 = 3" Insulation UL2221 4 = 4" insulation G = 4" insulation UL2221

PRODUCT WEIGHTS

The average weight of the duct, per foot of length, can be calculated using the following formula:

- PSW: 0.40 x diameter = lbs per foot
- PIC: 0.80 x diameter = lbs per foot
- IPIC-1/1G/1GV: 0.95 x diameter = lbs per foot
- IPIC-2/2G/2GV: 1.05 x diameter = lbs per foot
- IPIC-3/3G/3GV: 1.45 x diameter = lbs per foot
- IPIC-4/4G/4GV: 1.45 x diameter = lbs per foot

Example: 8IPIC-2: 1.05 x 8 = 8.4 lbs per foot

Duct design should provide adequate support to ensure duct components are not overloaded.

THERMAL EXPANSION CALCULATIONS

Thermal expansion under normal operating temperatures can fatigue welds causing leakage. It is necessary to calculate the thermal expansion between fixed points. Thermal expansion can be determined by using the following formula:

$$[\text{Length (ft)} / 100] \times [\text{Temperature Rise degrees F} / 100]$$

Example: [50' / 100] x [75F / 100] = 0.375" Expansion

If the computed expansion between fixed points is greater than 0.375", Metal-Fab recommends an Adjustable Length (AL) be installed.

SUPPORTS

PLATE & WALL SUPPORTS

TABLE 4 - MAXIMUM SUPPORTED HEIGHT

SUPPORT METHOD	MAXIMUM SUPPORTED HEIGHT				
	PSW	PIC	IPIC-1	IPIC-2	IPIC-4 / 4G IPIC-3 / 3G
WALL SUPPORT	40 (12.2)	40 (12.2)	34 (10.5)	30 (9.1)	29 (8.8)
APPLIANCE OR PIER OUTLET	100 (30.5)	100 (30.5)	85 (25.9)	75 (22.9)	73 (22.3)
PLATE SUPPORT ASSEMBLY	100 (30.5)	100 (30.5)	85 (25.9)	75 (22.9)	73 (22.3)
ROOF SUPPORT ASSEMBLY	N/A	30 (9.1)	25 (7.6)	22 (6.7)	22 (6.7)

The above figures represent vertical distance between supports, in feet (m).

PLATE SUPPORT (PS)

Plate Supports are designed to provide maximal support to vertical sections and provide fixed-point support for horizontal sections.

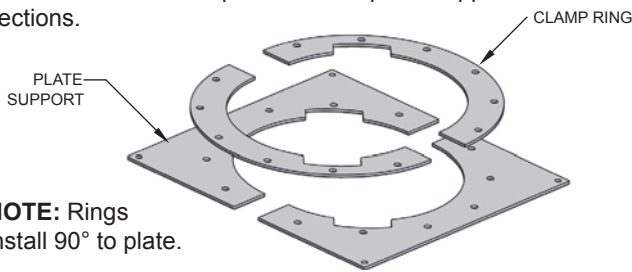

NOTE: Rings install 90° to plate.

The Plate Support must be attached to the building structure or supported with rigid structural members. See **Table 4** for maximum supported height.

A Plate Support is to be attached only to non-combustible construction such as block, concrete or steel with clearance that is adequate for installation and access.

WARNING: DO NOT ATTACH THE PLATE SUPPORT TO COMBUSTIBLE CONSTRUCTION.

For maximum support, the entire perimeter of the Plate Support must be attached to structural framing (See **FIG. 1**). Structural members are supplied by the installer.

FIG. 1 - SECTIONAL DETAIL FOR PLATE SUPPORT

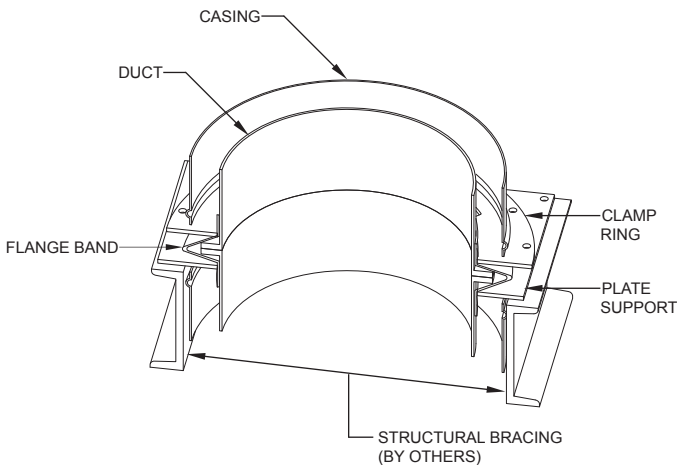

Supported duct sections subject to thermal expansion or in a vertical position must be braced with diagonal members or gussets to prevent deflection of the supported joint as shown in **FIG. 2**. "X" is a minimum of 30°.

FIG. 2 - PLATE SUPPORT BRACING

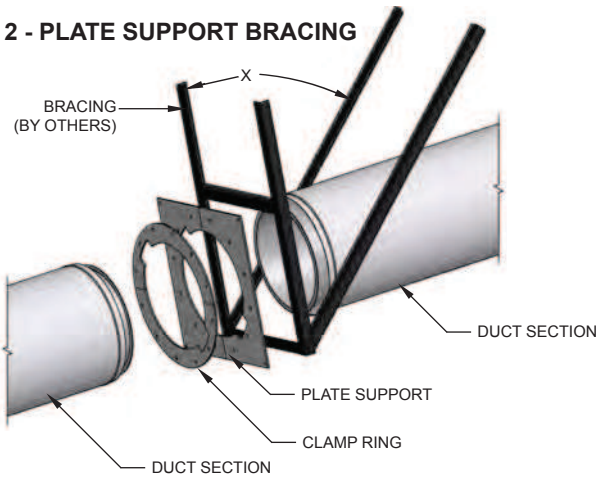

Plate Supports are usually located adjacent to fittings, such as tees or elbows, to protect fitting from expansion stresses. **Table 5** shows Plate Support, bracing and framework requirements for duct size ranges.

TABLE 5-PLATE SUPPORT, BRACE & FRAMING MATERIAL

DUCT DIA.	PS PLATE THICKNESS	BRACING FOR PLATE SUPPORT HEIGHT OF STACK	
		50' (15.24m)	100' (30.48m)
6"-20"	3/16" (5)	1 1/4" x 1 1/4" x 1/8" (32 x 32 x 3)	2" x 2" x 1/4" (51 x 51 x 6)
22"-36"	1/4" (6)	2" x 2" x 1/8" (51 x 51 x 3)	3" x 3" x 1/4" (76 x 76 x 6)
38"-48"	1/4" (6)	3" (76) channel: 3" x 1 1/2" x 1/4" (76 x 38 x 6)	
DUCT DIA.	PS PLATE THICKNESS	FRAME WORK FOR PLATE SUPPORT HEIGHT OF STACK	
		50' (15.24m)	100' (30.48m)
6"-20"	3/16" (5)	1 3/4" x 1 3/4" x 1/8" (44 x 44 x 3)	3" x 2" x 3/16" (76 x 51 x 5)
22"-36"	1/4" (6)	2" x 2" x 1/4" (51 x 51 x 6)	4" x 3" x 1/4" (102 x 76 x 6)
38"-48"	1/4" (6)	3" (76) channel: 3" x 1 1/2" x 1/4" (76 x 38 x 6)	

A welded frame must be adequately attached to structural member for framework rigidity if bracing is not used.

WARNING: DO NOT INSULATE STRUCTURAL SUPPORTS.

Duct heights in excess of single Plate Support capability can be resupported with additional Plate Support(s). An expansion joint must be used between support points (See **FIG 3**).

FIG. 3 - RESUPPORT REQUIREMENTS

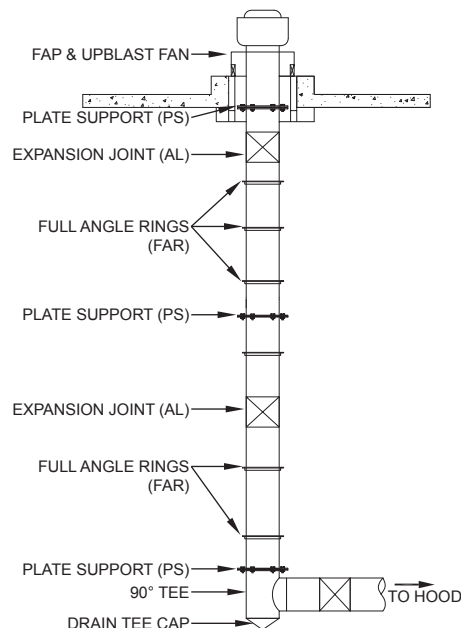

WALL SUPPORT ASSEMBLY (WSA)

When attached to a non-combustible wall with brackets and struts, a Wall Support Assembly makes up a fixed-point (See FIG. 4). The clamp rings are installed with the splits 90° apart so that they support each other. The notches in the clamp rings are aligned with the draw screws of the flange band. The Wall Support Assembly is bolted together with provided hardware.

An Expansion Joint is required between the Wall Support Assembly and any adjacent fixed point. Multiple Wall Support Assemblies may be used, in conjunction with expansion joints, to support duct heights in excess of the allowable height for a single Wall Support Assembly (See Table 4 on page 6).

FIG. 4 - WALL SUPPORT ASSEMBLY

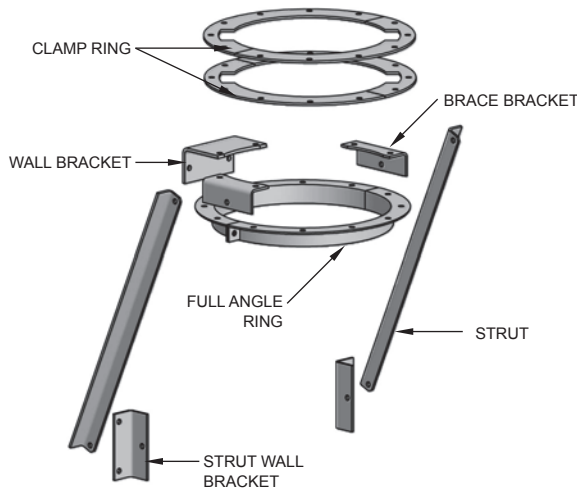

NOTE: Do not attach Wall Support Assembly to combustible construction.

NOTE: Wrap duct joint with insulation before attaching half closure band.

WALL GUIDE (WG)

The Wall Guide is designed to compliment the Wall Support Assembly (See Fig. 5). It is used as a lateral guide to prevent the duct from flexing due to lateral loading. The proper location for a Wall Guide is immediately below the outer closure band near the duct joint. The outer band must be able to move away from the Wall Guide when thermal expansion occurs (See FIG. 6). The Wall Guide is bolted together with hardware provided to form a rigid assembly.

FIG. 5 - WALL GUIDE EXPLODED VIEW

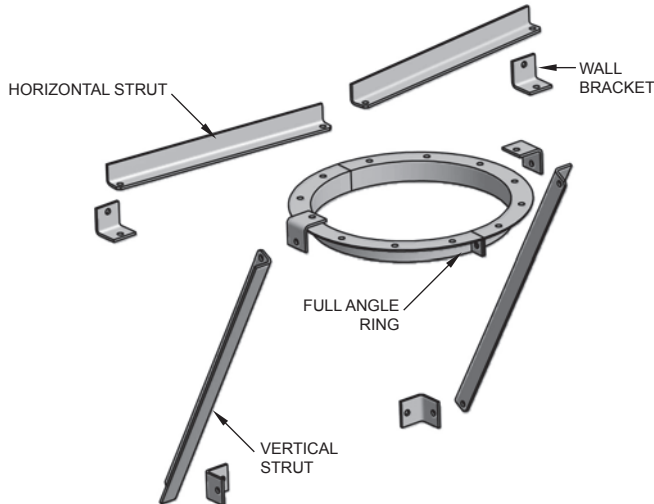

NOTE: Seal joint with P077 sealant above and below support if exposed to weather.

SPECIAL CONSIDERATIONS

(Wall Support Assembly & Wall Guide)

When a Wall Support Assembly is used to support a duct on an exterior wall, wind loading must also be considered. Below the highest Wall Support Assembly, the duct must be resupported at intervals not greater than 40' (12.19m). The duct must be equipped with Wall Guides between each Wall Support Assembly. See Table 6 for maximum guide spacing.

TABLE 6 - MAXIMUM SPACING FOR WALL GUIDES

DUCT DIAMETER	DUCT MODEL		
	PSW, PIC, 1G, 1GV & IPIC-1	2G, 2GV & IPIC-2	3G, 3GV & IPIC-3, 4G, 4GV & IPIC-4
6"	17'-0" (5.18m)	10'-6" (3.20m)	8'-3" (2.51m)
8"	17'-6" (5.33m)	12'-0" (3.66m)	9'-7" (2.92m)
10"	18'-6" (5.64m)	13'-3" (4.04m)	10'-9" (3.28m)
12"	20'-0" (6.10m)	14'-6" (4.42m)	11'-11" (3.63m)
14"	21'-0" (6.40m)	15'-11" (4.85m)	13'-2" (4.01m)
16"	22'-0" (6.71m)	17'-0" (5.18m)	14'-2" (4.32m)
18"	23'-0" (7.01m)	18'-3" (5.56m)	15'-4" (4.67m)
20"	24'-0" (7.32m)	19'-6" (5.94m)	16'-4" (4.98m)
22"	24'-6" (7.47m)	20'-2" (6.15m)	17'-0" (5.18m)
24"	25'-0" (7.62m)	20'-9" (6.32m)	17'-7" (5.26m)
26"	26'-0" (7.92m)	21'-5" (6.53m)	18'-2" (5.54m)
28"	27'-0" (8.23m)	22'-1" (6.73m)	18'-9" (5.72m)
30"	27'-0" (8.23m)	22'-8" (6.91m)	19'-4" (5.89m)
32"	28'-6" (8.69m)	23'-4" (7.11m)	19'-11" (6.07m)
34"	29'-0" (8.84m)	24'-0" (7.32m)	20'-6" (6.25m)
36"	30'-0" (9.14m)	24'-7" (7.49m)	21'-0" (6.40m)
38"	30'-6" (9.30m)	24'-7" (7.49m)	21'-0" (6.40m)
40"	31'-0" (9.45m)	24'-7" (7.49m)	21'-0" (6.40m)
42"	32'-0" (9.75m)	24'-7" (7.49m)	21'-0" (6.40m)
44"	32'-6" (9.91m)	24'-7" (7.49m)	21'-0" (6.40m)
46"	33'-6" (10.21m)	24'-7" (7.49m)	21'-0" (6.40m)
48"	34'-6" (10.52m)	24'-7" (7.49m)	21'-0" (6.40m)

Additionally, a Wall Guide must be located between 6' (1.83m) and 10' (3.05m) below the highest Wall Support Assembly to stabilize the freestanding portion of the duct above the Wall Support Assembly (See FIG. 6)

FIG. 6 - SPECIAL CONSIDERATIONS FOR GREASE DUCT ON OUTSIDE WALL

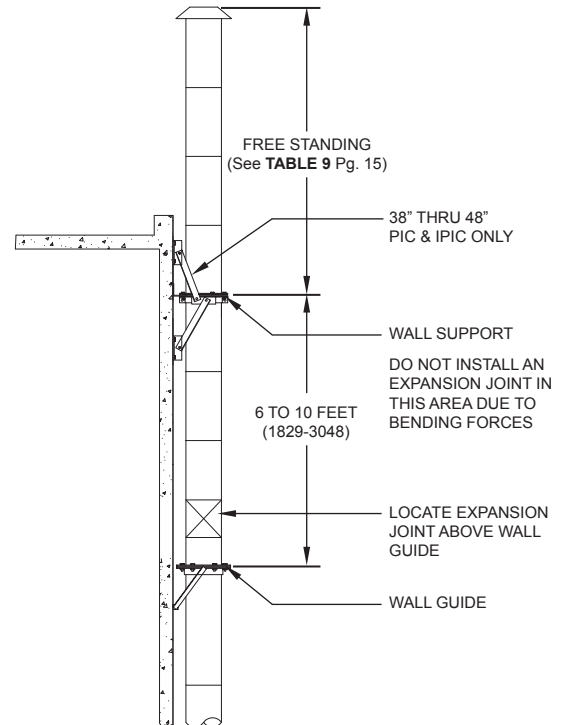

FLOOR GUIDE (FG)

A Floor Guide is similar in function to a Wall Guide or Full Angle Ring, but is modified specifically for use at floor penetrations. The angle brackets and straps hold the Floor Guide centered in floor penetration. Maximum floor opening "X" is Duct I.D. + 10" (254).

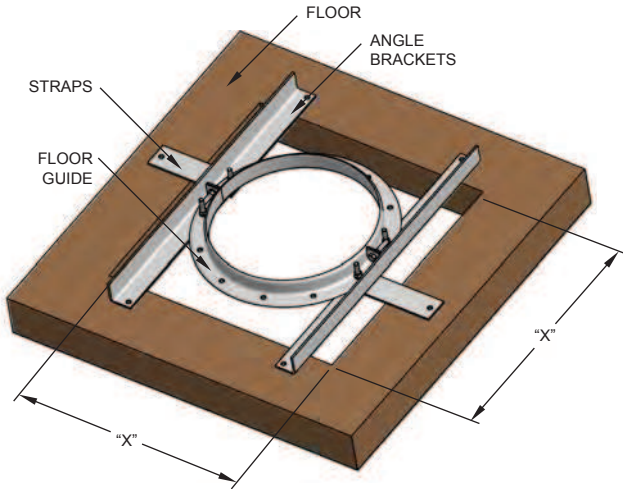

NOTE: Do not attach the Floor Guide to combustible construction.



FULL ANGLE RING (FAR)

A Full Angle Ring is used as a guide to prevent the duct from flexing due to lateral loading. The angle ring is split for ease of installation. It is 1/8" larger in inside diameter than the outside diameter of the duct to allow movement of the duct inside the ring (See FIG 7).

FIG. 7 - FULL ANGLE RING FOR LATERAL SUPPORT

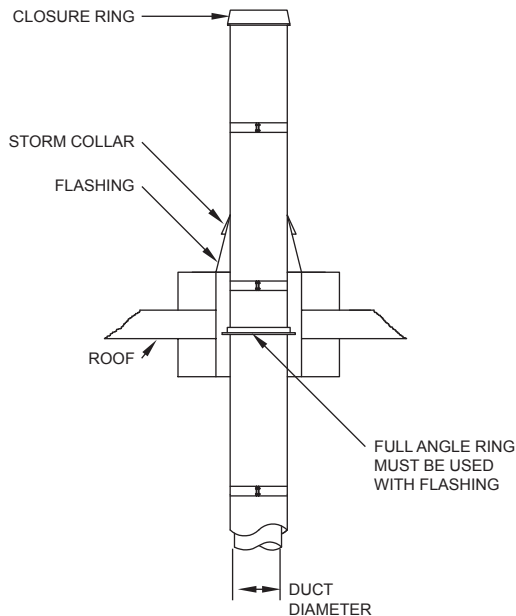

TABLE 7 provides maximum horizontal distance between supports for various support types.

TABLE 7

SUPPORT - HORIZONTAL	Max. Distance Between Supports		
	PSW & PIC	1G	2G, 3G & 4G
Half Angle Ring (HAR)	12' 6" (2.7m)	10' (3.1m)	9' (2.7 m)
Full Angle Ring (FAR)	12' 6" (2.7m)	10' (3.1m)	9' (2.7 m)
Plate Support (PS)	12' 6" (2.7m)	10' (3.1m)	9' (2.7 m)

TABLE 8 provides the maximum distance between Guides for Grease Ducts installed inside a building (For exterior installations, See **TABLE 6**)

TABLE 8

GUIDES - VERTICAL	Max. Distance Interior (Inside Building)			
	PSW & PIC	1G	2G	3G & 4G*
Full Angle Ring	25' (7.6m)	21' (6.4m)	19' (5.7m)	18' (5.5m)

* Check with local jurisdiction for approval to use and guide Series 4G sizes that exceed 36" Dia.



HALF ANGLE RING (HAR)

A Half Angle Ring is used as a saddle in horizontal or sloped runs.

SUPPORTS – INSTALLATION LOCATIONS

Supports can be used in different combinations to secure grease duct in place. See **FIG. 8** for typical support locations.

FIG. 8 - TYPICAL SUPPORT LOCATIONS

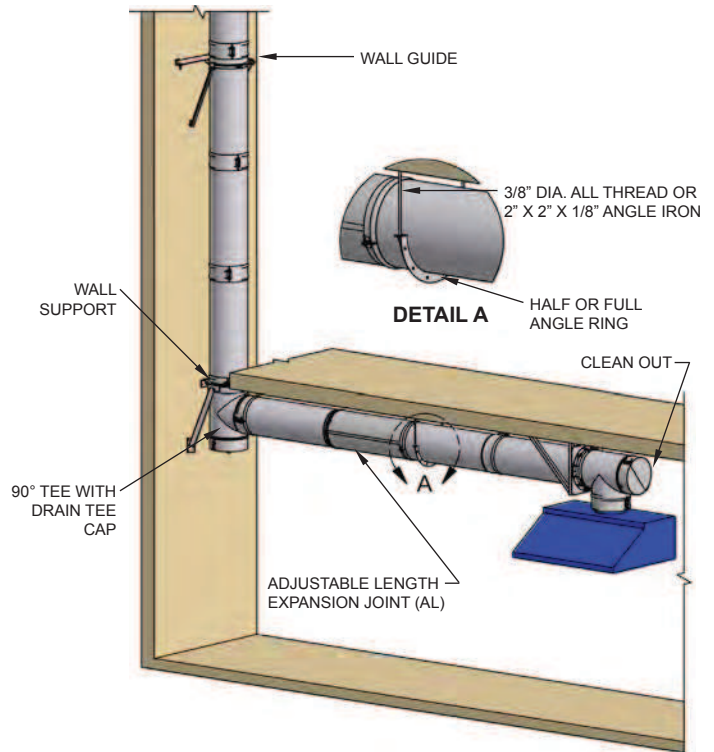

VARIABLE & ADJUSTABLE LENGTH SUPPORT

It is recommended that the duct section adjacent to a Variable Length or an Adjustable Length is supported or guided to prevent sagging. FIG. 9 shows an Adjustable Length being supported with a Wall Support Assembly (WSA). FIG. 10 shows an Variable Length being guided with a Half Angle Ring (HAR).

FIG. 9 - ADJUSTABLE LENGTH SUPPORTED WITH WSA

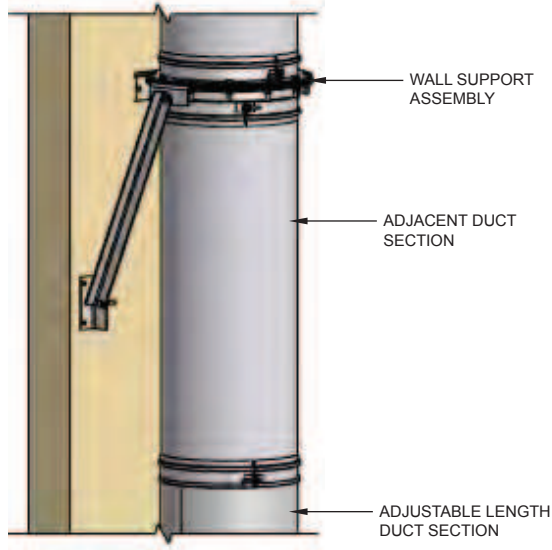

NOTE: Flange of adjacent duct section is to be secured in place between the Clamp Rings.

NOTE: When necessary, properly guide an Adjustable Length by installing Wall Guide immediately below duct joint on adjacent duct section. The outer band must be able to move away from the Wall Guide when thermal expansion occurs (See FIG. 6).

FIG. 10 - VARIABLE LENGTH SUPPORT WITH HAR

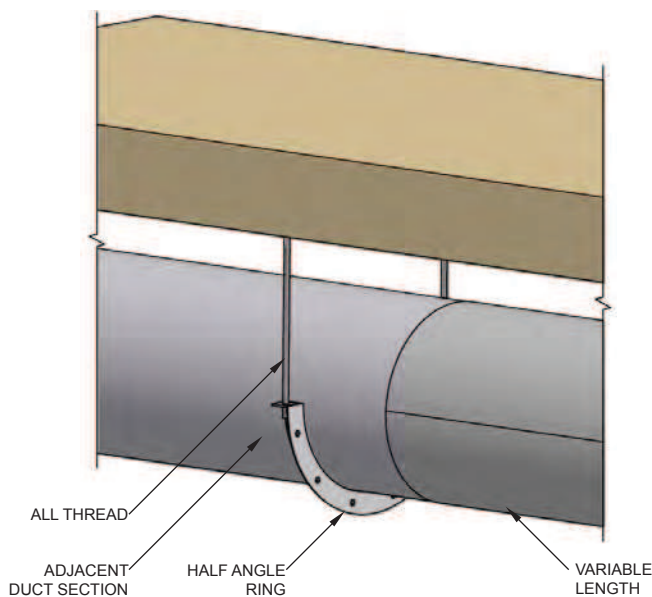

ELBOW SUPPORT

Elbows are to be supported on one end with either a Plate Support (PS) as shown in FIG. 11 or a Wall Support Assembly (WSA) as shown in FIG. 12.

FIG. 11 - ELBOW SUPPORTED WITH PS

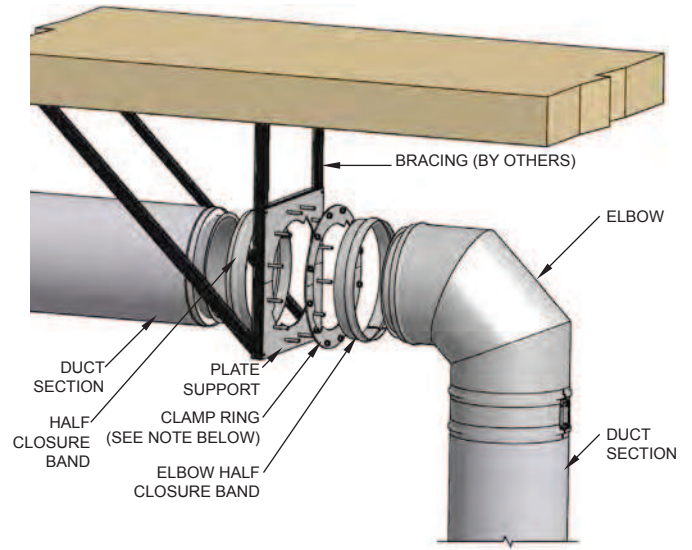

NOTE: Flange joint of duct and elbow are to be secured in place between the Clamp Ring and Plate Support.

FIG. 12 - ELBOW SUPPORTED WITH WSA

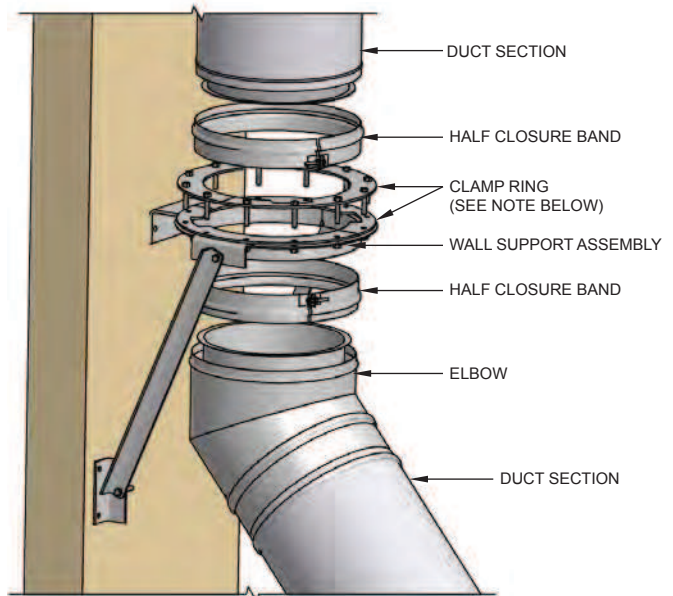

NOTE: Flange joint of duct and elbow are to be secured in place between the Clamp Rings.

Elbows are not designed to resist bending loads and must be protected by structural reinforcement. FIG. 13 depicts some alternative methods for protection of elbows.

FIG. 13 - ELBOW STRUCTURAL REINFORCEMENT METHODS

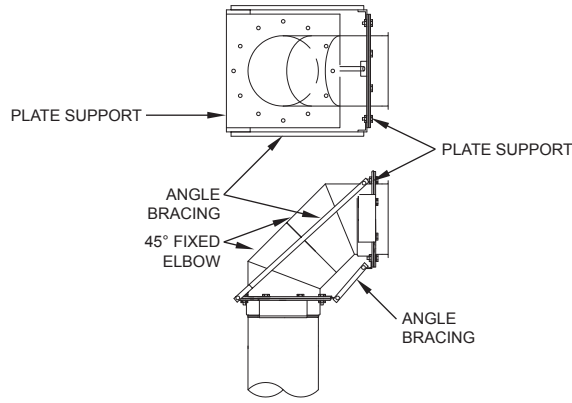

2-45° ELBOWS REINFORCED WITH PLATE SUPPORTS

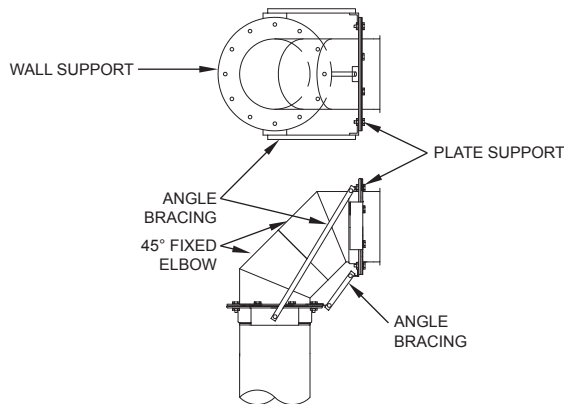

2-45° ELBOWS REINFORCED WITH WALL SUPPORTS

TEE SUPPORT

Tees are to be supported by using a Wall Support Assembly (WSA) or by using a Plate Support (PS). When a tee is used at the base of the riser, the preferred location for support is above the Tee, thus suspending the Tee (See FIG. 14).

FIG. 14 - SUSPENDED TEE SUPPORT

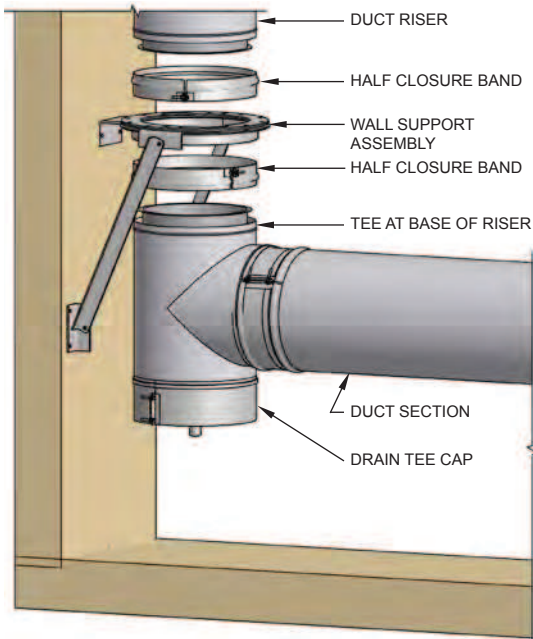

NOTE: Flange joint of duct and Tee are to be secured in place between the Clamp Rings.

If it is not possible to suspend the Tee, it may be supported with a base (FIG. 15). When a base is necessary, access to the Drain Bucket may be hindered. A drain bucket should be used under the Tee to allow access to the Tee Cap.

FIG. 15 - BASE TEE SUPPORT

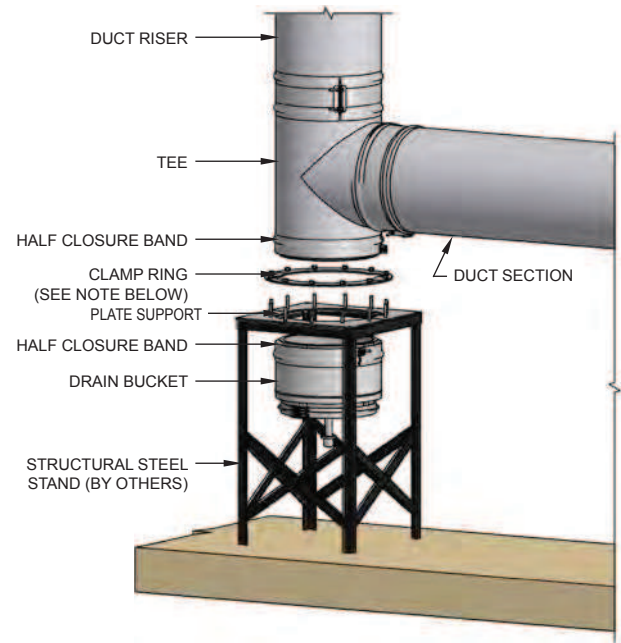

NOTE: Flange joint of Tee and Drain Bucket are to be secured in place between the Clamp Ring and Plate Support.

When a 45° Tee or Double Lateral Tee is used, it is important to isolate the 45° Tee from thermal expansion. This isolation is typically accomplished by using a two-axis support (See FIG. 16).

FIG. 16 - TWO-AXIS SUPPORT

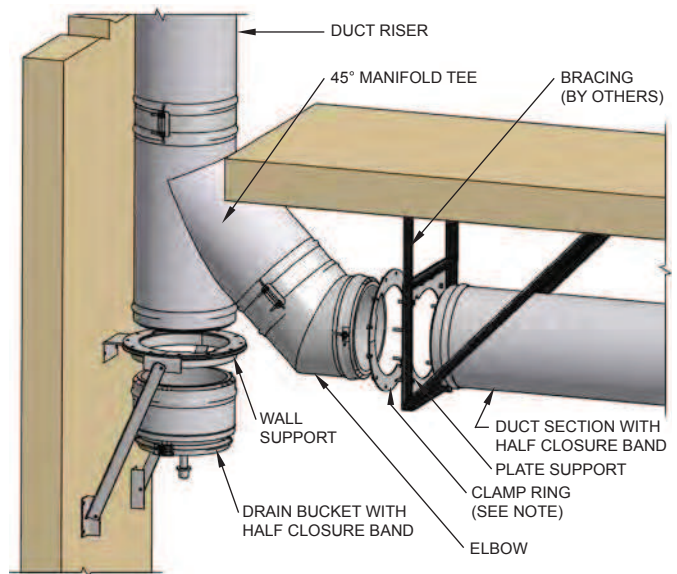

NOTE: Flange joint of Elbow and duct are to be secured in place between the Clamp Ring and Plate Support. Flange joint of 45° Tee and Drain Bucket to be secured in place between the Wall Support Assembly Clamp Rings.

When 90° or 45° Tees are used to manifold multiple appliances together, it is important to make provisions for expansion of the manifold. An expansion joint should be installed between Tees (See FIG. 17). The manifold must be supported properly by means of Plate Supports or Wall Support Assemblies arranged to protect the Tees from bending forces.

FIG. 17 - LATERAL TEE MANIFOLD SUPPORT

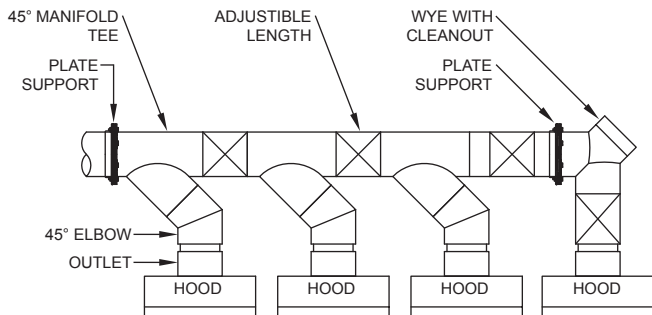

THROUGH FLOOR (FIRESTOP) SUPPORT

Ducts that penetrate a fire-resistance floor will need to be supported on either the top side of floor or bottom side of floor. Top side duct support can be done by bracing a Plate Support while bottom side support can be done by suspending a Plate Support (See FIG. 18.)

NOTE: Duct support is used in addition to a Penetration Firestop System (PPK). PPK must be installed on top side of floor. See Firestop section for installation of the PPK.

NOTE: Hole cut in floor shall be 2”(54) greater than duct O.D.

FIG. 18 - FLOOR FIRESTOP SUPPORT

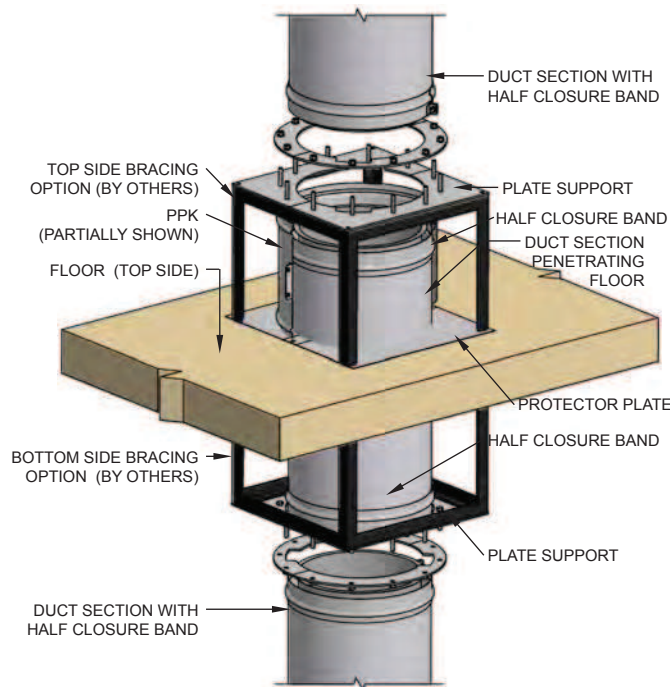

NOTE: Flange joint of duct penetrating floor and adjacent duct are to be secured in place between the Clamp Ring and Plate Support.

PENETRATIONS

THIMBLES

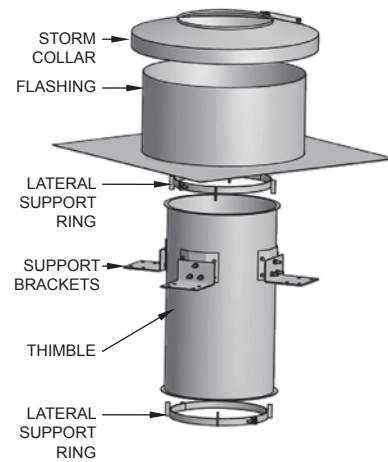

VENTILATED THIMBLE (VTA)

The Ventilated Thimble Assembly is designed to allow PIC and IPIC grease ducts to penetrate a combustible roof at a nominal 3” clearance to combustibles. It is intended for installation on a flat roof. It may be used on a pitched roof if a curb is installed at the penetration to provide a level surface for mounting the thimble.

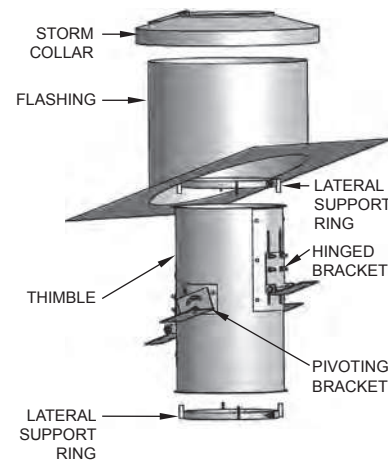

FIXED PITCH VENTILATED THIMBLE ASSEMBLY (FPVTA)

The FPVTA is a special variation of the Ventilated Thimble Assembly (VTA). It provides the same clearance to combustibles and types of supports as the VTA, but the FPVTA is designed to be installed in pitched roofs. Roof pitch must be specified when ordering.

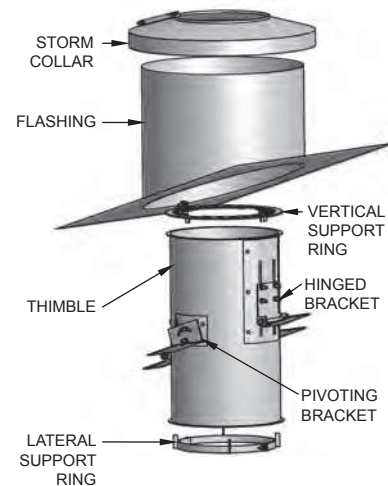

FIXED PITCH ROOF SUPPORT ASSEMBLY (FPRSA)

The Fixed Pitch Roof Support Assembly is a special variation of the FPVTA which provides vertical support to the duct. It is especially useful when the duct rise below the roof is long enough to cause movement from thermal expansion that exceeds approximately 2” (51). Roof pitch must be specified when ordering.

VTA, FPVTA & FPRSA INSTALLATION:

1. Cut the roof opening and reinforce the edges of the hole as appropriate for the expected load bearing requirements. See FIG. 19-1 for minimum opening dimensions. Attach the thimble brackets to the thimble using the hardware provided.

FIG. 19.1 - ROOF OPENING MINIMUM DIMENSIONS

FLAT ROOF

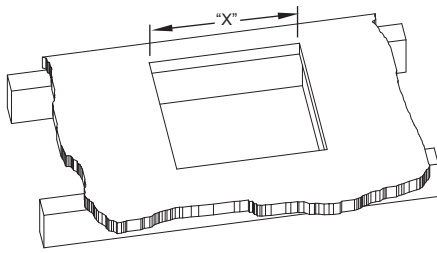

SLOPED ROOF

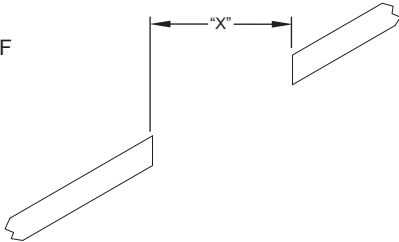

MODEL	PIC & IPIC-1	IPIC-2	IPIC-3G	IPIC-4 & IPIC-4G
"X"	I.D. + 8"	I.D. + 10"	I.D. + 12"	I.D. + 14"

- Set the thimble through the roof, making sure it is centered in the roof penetration hole, and secure it to the roof deck with supplied bolts or lag screws. The brackets may be welded to a metal roof, if desired.

(FPVTA & FPRSA only) Leave the bolts of the sliding mount loose until all four brackets are attached to roof (See FIG. 19-2). Then tighten all bolts and nuts.

FIG. 19.2 - FIXED PITCH ROOF

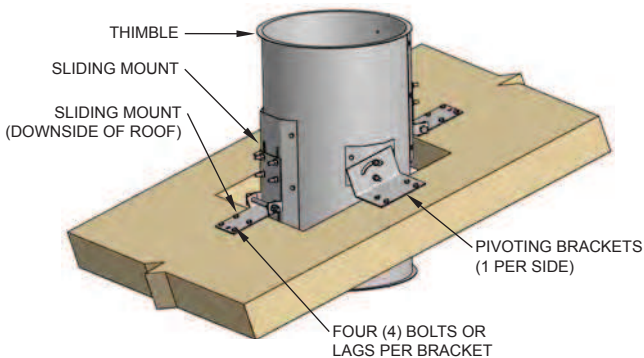

- Install the duct passing through the thimble and extending above the roof (See FIG. 19-5).
- (FPRSA only)** The duct is supported with a Vertical Support Ring in lieu of the Lateral Support Ring on the top side of thimble. After connecting the duct section joints together with flange band, install the Vertical Support Ring halves (See FIG. 19-4). The support ring should be installed directly underneath the bottom side of flange band. With Vertical Support Ring secured to the duct, it can be lowered so that the ring rests on top of the thimble.

FIG. 19.4 - VERTICAL SUPPORT RING

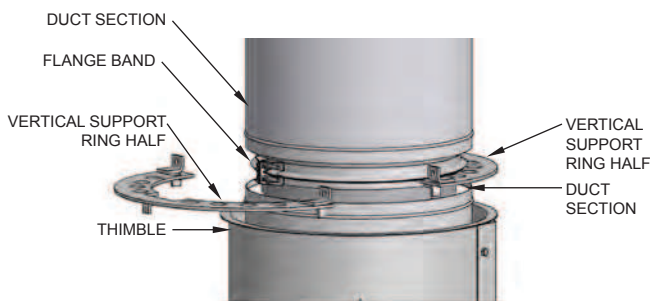

(VTA and FPVTA only) Install the two split lateral support rings on the duct casing, one above the thimble and one below the thimble. Leave the bolts loose enough to allow ring to slide along the casing. The spacer tabs are to point towards thimble (See FIG. 19-5).

- Push the support rings along the duct casing until the rings are completely enclosed in the thimble (See FIG. 19-5).

FIG. 19.5 - LATERAL RINGS

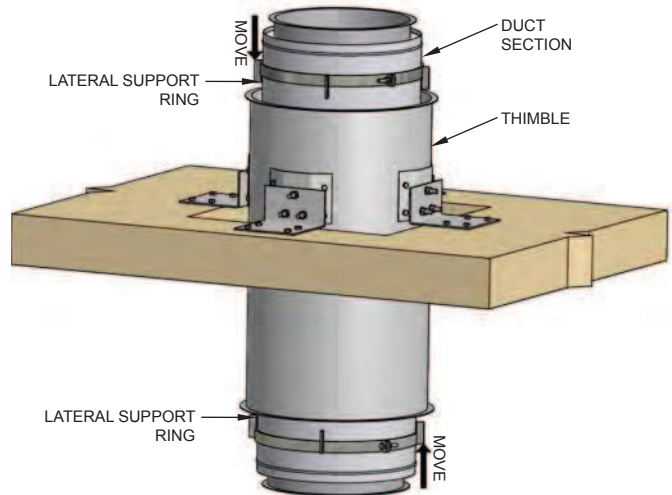

- Install the flashing centered on the thimble. Secure it to the roof and seal it to the roof membrane as appropriate (See FIG. 19-7).
- Install the storm collar around the duct casing allowing the ventilation spacers on the underside of the collar to rest on upper edges of flashing. Tighten the draw screws and seal between the collar and duct casing with sealant (See FIG. 19-7).

FIG. 19.7 - STORM COLLAR, FLASHING AND SEAL

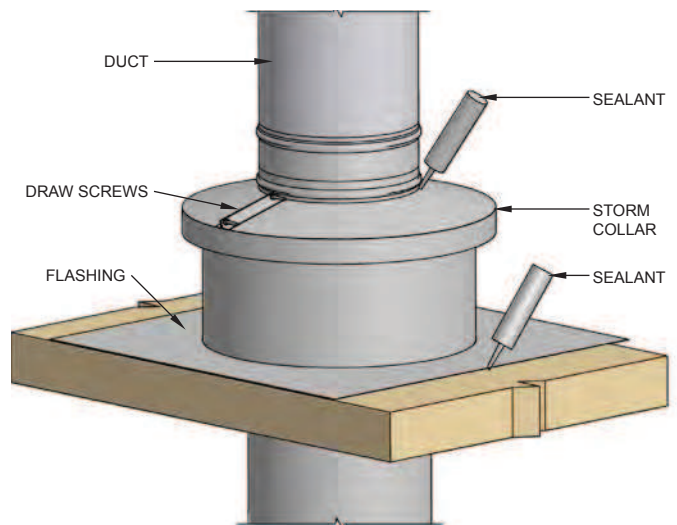

NOTE: If using ceramic insulated duct, the joint will need to be insulated prior to installing the flashing and storm collar. Since joint is fully encased in FPRSA, a casing closure band is not required.

FLASHING (F), FIXED PITCH FLASHING (FPF) AND STORM COLLAR (SC)

Flashings both standard (tall cone) and pitched, are intended for installation on non-combustible roofs only.

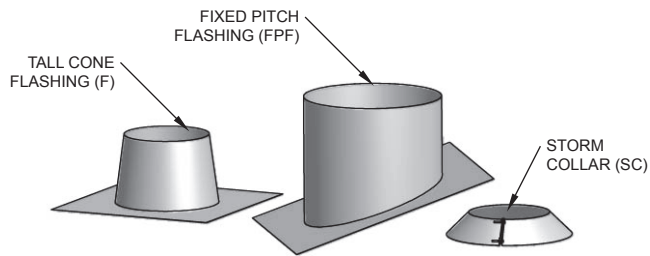

The flashing is non-ventilated and does not provide for any reduced clearance to combustibles. To install the flashing, place it around the duct. Secure and seal it to the roof (See FIG. 20).

FIG. 20 - STORM COLLAR, FLASHING AND SEAL

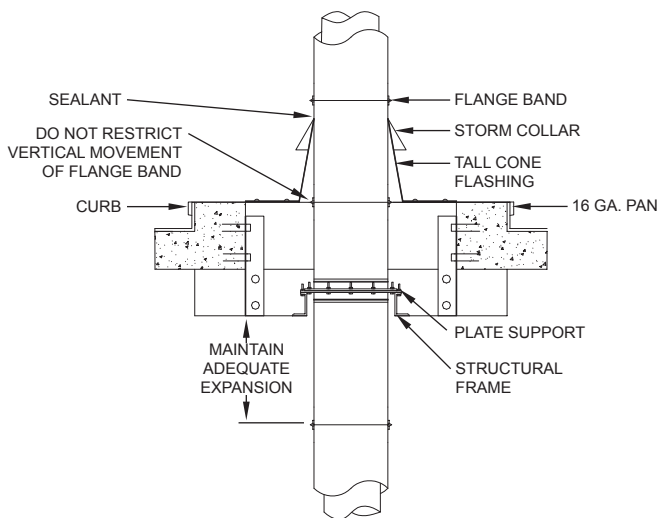

With the flashing in place, the storm collar is placed around the duct and sealed to the casing with silicone sealer. The storm collar should not quite rest on the flashing when the duct is cold (1/4" gap between the collar and the top of flashing).

When a duct is installed with a flashing and collar rather than a Ventilated Thimble, the duct must be stabilized by installing either a Full Angle Ring or Plate Support just below the roof. **If the maximum free standing duct height above the Plate Support or Full Angle Ring exceeds that shown in Table 9 located on page 15, guying is required.**

FIRESTOPS

FIRESTOP KIT (PPK)

When penetrating a fire-resistance rated floor or wall, a Firestop Kit (PPK) is to be used to retain the fire resistance rating on the floor and walls. PPK consists of one 12" wide ceramic fiber, one 3 1/2" wide ceramic fiber, two closure bands and required tubes of caulk. Use only the Metal-Fab model PPK Firestop with the Metal-Fab grease duct.

Floor / Ceiling Firestop Installation:

1. Cut a circular hole in the floor/ceiling that is 2" (51) greater than the duct O.D (See FIG. 21-1). Center the duct within the hole and support the duct to maintain location. See Through Floor (Firestop) Support section on page 11 for typical support procedures.

FIG. 21-1

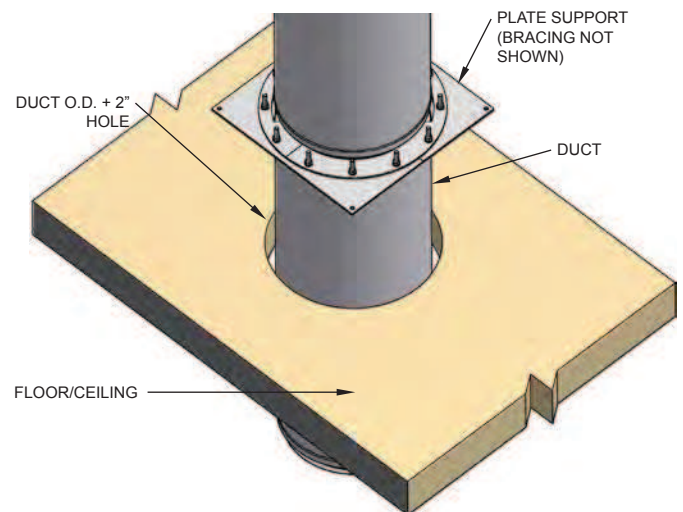

2. Insert the provided 3 1/2" (89) wide insulation into the cavity between floor/ceiling and duct. The insulation must encircle the outer duct casing and fill the cavity within 1/2" (13) of the floor/ceiling surface (See FIG. 21-3). Pack the insulation within the cavity if required.
3. On upstream side of floor/ceiling, side closest to appliance, apply the caulk provided to a depth of 1/2" (13) around the duct (See FIG. 21-3). Caulk is P082 – 3M part number CP25WB+ or HILTI FS-ONE.

FIG. 21-3

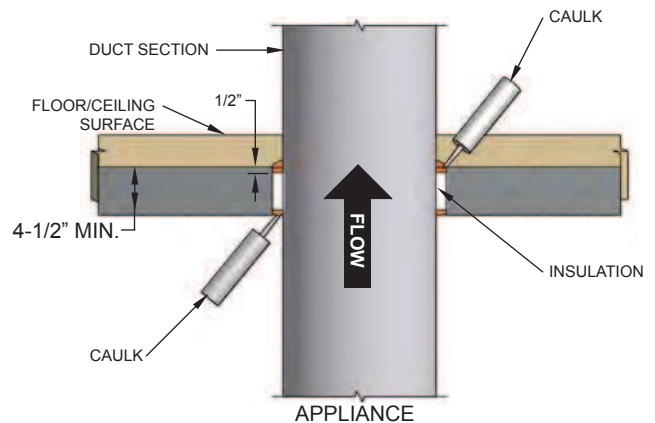

NOTE: The opening between the duct and the floor must be closed.

4. Apply caulk to a depth of 1/2" (13) on downstream side of floor/ceiling, filling the cavity (See FIG. 21-3).
5. Install two (2) halves of protector plate to the top side of the floor/ceiling (See FIG. 21-6). Secure with masonry hardware.

NOTE: The protector plate halves are designed to fit around the duct casing and overlap each other 1/2" (13).

6. Install the 12" (305) wide insulation around the duct casing on the upstream side of floor/ceiling. The insulation is to be resting on top of the protector plates (See FIG. 21-6). With insulation in place, position the closure band around the insulation and tighten retaining bolts.

FIG. 21-6

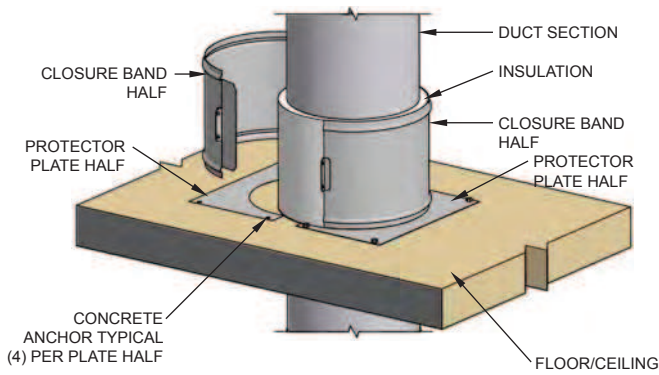

Wall (Concrete) Firestop Installation:

Through penetration through a concrete wall is similar to the floor/ceiling installation except for the following:

1. The duct has to be properly supported on each side of the wall penetration. Hole cut in wall shall be 2" (54) greater than duct O.D.
2. A Firestop Kit (PPK) has to be used on each side of the wall penetration as shown in FIG. 22.

FIG. 22 - PPK (2 ea.) PER WALL

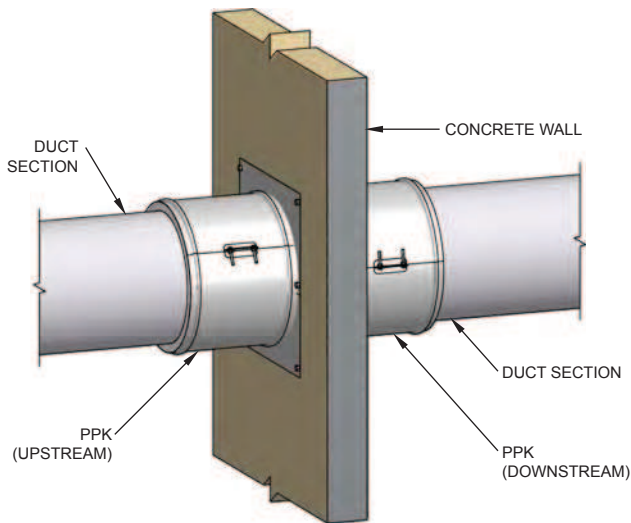

Wall (Gypsum 1-HR/2-HR) Firestop Installation:

The IPIC-2G, IPIC-3G & IPIC-4G duct is allowed to penetrate through 1-HR or 2-HR fire rated walls that are constructed of steel stud construction and minimum 5/8" gypsum board. IPIC-2G, 18" max. I.D., IPIC-3G, 24" max. I.D., and IPIC-4G, 28" max I.D., can penetrate both 1-HR and 2-HR fire rated walls. A PPK kit is required to be installed on each side of the wall penetration. Installation is as follows:

1. Cut a circular hole in the wall that is 1.5" (38) greater than the duct O.D (See FIG. 23-1). Center the duct within the hole and properly support duct on each side of wall penetration.

FIG. 23-1

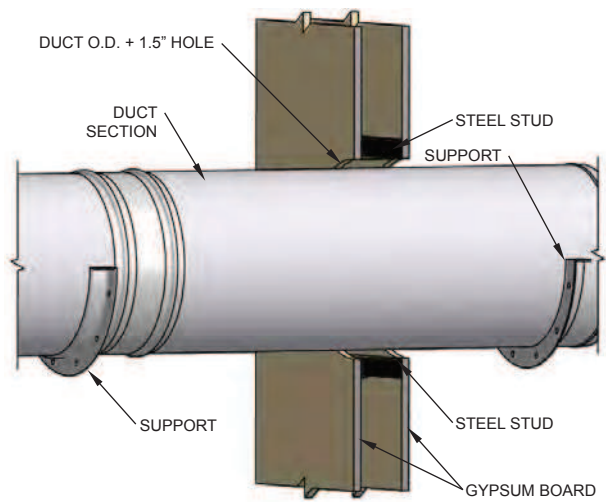

2. Insert the provided 3 1/2" (89) wide insulation into the cavity between wall and duct. The insulation must encircle the outer duct casing and fill the cavity within 1/2" (13) of the wall surface (See FIG. 23-3). Pack the fiber within the cavity if required.

NOTE: A metal tape can be used to secure insulation around the duct if necessary.

3. On the side of wall closest to appliance, apply the caulk provided to a depth of 1/2" (13) around the duct (See FIG. 23-3). Caulk is HILTI FS-ONE (see UL Design W-L-7124).

FIG. 23-3

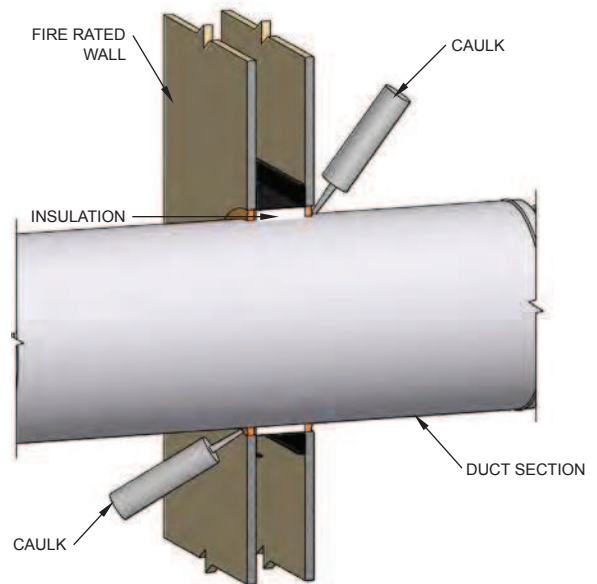

NOTE: The opening between the duct and the wall must be closed.

4. Apply caulk to a depth of 1/2" (13) from the other side of wall, filling the cavity (See FIG. 23-3).
5. Install two (2) halves of protector plate to the side of the wall (See FIG. 23-5). Secure with masonry hardware.

NOTE: The protector plate halves are designed to fit around the duct casing and overlap each other 1/2" (13).

FIG. 23-5

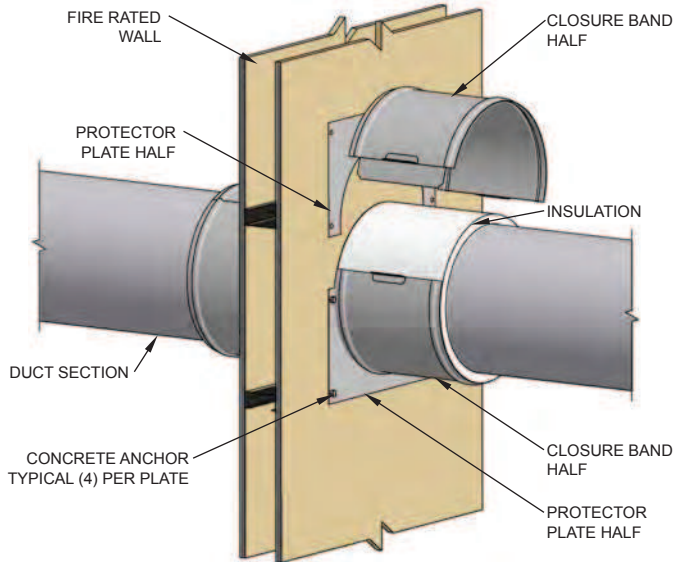

6. Install the 12" (305) wide insulation around the duct casing on one side of wall penetration. The insulation is to rest against the protector plates (See FIG. 23-5). With insulation in place, position the closure band around the insulation and tighten retaining bolts.
7. Repeat steps 5 and 6 for installing PPK on other side of wall penetration to provide symmetrical protection.

GUYING REQUIREMENTS

If maximum free standing height of duct above the roofline exceeds dimension "B" shown in FIG. 24, then guying is required. See TABLE 9 maximum heights per diameter size.

FIG. 24 - FREE-STANDING HEIGHT ABOVE ROOF

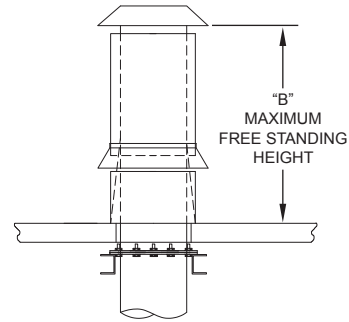
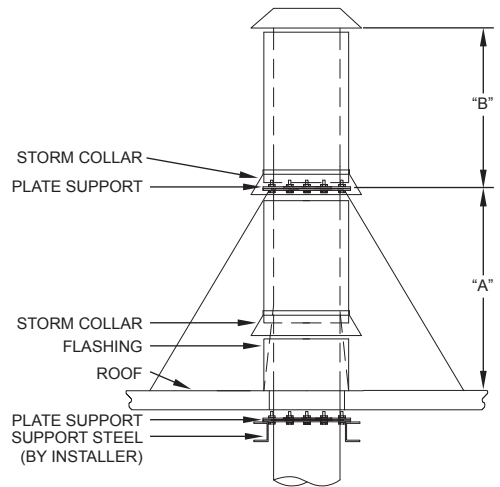

FIG. 25 - GUYING FOR SINGLE SECTION



NOTE: See TABLE 9 for "A" dimension and "B" dimension.

TABLE 9 - MAXIMUM FREE-STANDING HEIGHT

DUCT DIAMETER	DUCT MODEL					
	PSW, PIC & IPIC-1		IPIC-2		IPIC-3 & IPIC-4	
	"A"	"B"	"A"	"B"	"A"	"B"
6"	17'-0" (5.18m)	8'-6" (2.59m)	10'-6" (3.20m)	7'-11" (2.41m)	8'-3" (2.51m)	6'-8" (2.03m)
8"	17'-6" (5.33m)	8'-9" (2.67m)	12'-0" (3.66m)	8'-5" (2.57m)	9'-7" (2.92m)	7'-3" (2.21m)
10"	18'-6" (5.64m)	9'-3" (2.82m)	13'-3" (4.04m)	8'-11" (2.72m)	10'-9" (3.28m)	7'-9" (2.36m)
12"	20'-0" (6.10m)	10'-0" (3.05m)	14'-6" (4.42m)	9'-5" (2.87m)	11'-11" (3.63m)	8'-4" (2.54m)
14"	21'-0" (6.40m)	10'-6" (3.20m)	15'-11" (4.85m)	9'-11" (3.02m)	13'-2" (4.01m)	8'-11" (2.71m)
16"	22'-0" (6.71m)	11'-0" (3.35m)	17'-0" (5.18m)	10'-6" (3.20m)	14'-2" (4.32m)	9'-6" (2.90m)
18"	23'-0" (7.01m)	11'-6" (3.51m)	18'-3" (5.56m)	11'-0" (3.35m)	15'-4" (4.67m)	10'-1" (3.07m)
20"	24'-0" (7.32m)	12'-0" (3.66m)	19'-6" (5.94m)	11'-6" (3.51m)	16'-4" (4.98m)	10'-8" (3.25m)
22"	24'-6" (7.47m)	12'-3" (3.73m)	20'-2" (6.15m)	11'-10" (3.61m)	17'-0" (5.18m)	11'-0" (3.35m)
24"	25'-0" (7.62m)	12'-6" (3.81m)	20'-9" (6.32m)	12'-3" (3.73m)	17'-7" (5.26m)	11'-6" (3.51m)
26"	26'-0" (7.92m)	13'-0" (3.96m)	21'-5" (6.53m)	12'-6" (3.81m)	18'-2" (5.54m)	11'-10" (3.61m)
28"	27'-0" (8.23m)	13'-6" (4.11m)	22'-1" (6.73m)	13'-1" (3.99m)	18'-9" (5.72m)	12'-4" (3.76m)
30"	27'-0" (8.23m)	13'-6" (4.11m)	22'-8" (6.91m)	13'-5" (4.09m)	19'-4" (5.89m)	12'-8" (3.86m)
32"	28'-6" (8.69m)	14'-3" (4.34m)	23'-4" (7.11m)	13'-10" (4.22m)	19'-11" (6.07m)	13'-2" (4.01m)
34"	29'-0" (8.84m)	14'-6" (4.42m)	24'-0" (7.32m)	14'-3" (4.34m)	20'-6" (6.25m)	13'-6" (4.11m)
36"	30'-0" (9.14m)	15'-0" (4.57m)	24'-7" (7.49m)	14'-7" (4.45m)	21'-0" (6.40m)	13'-11" (4.24m)
38"	30'-6" (9.30m)	15'-3" (4.64m)	24'-7" (7.49m)	14'-11" (4.55m)	21'-0" (6.40m)	14'-3" (4.34m)
40"	31'-0" (9.45m)	15'-6" (4.72m)	24'-7" (7.49m)	15'-3" (4.64m)	21'-0" (6.40m)	14'-8" (4.47m)
42"	32'-0" (9.75m)	16'-0" (4.88m)	24'-7" (7.49m)	15'-9" (4.80m)	21'-0" (6.40m)	15'-2" (4.62m)
44"	32'-6" (9.91m)	16'-3" (4.95m)	24'-7" (7.49m)	16'-3" (4.95m)	21'-0" (6.40m)	15'-8" (4.78m)
46"	33'-6" (10.21m)	16'-9" (5.10m)	24'-7" (7.49m)	16'-6" (5.03m)	21'-0" (6.40m)	16'-0" (4.88m)
48"	34'-6" (10.52m)	17'-3" (5.26m)	24'-7" (7.49m)	17'-0" (5.18m)	21'-0" (6.40m)	16'-5" (5.00m)

NOTE: When duct is installed outside building, adjacent to wall, spacing between guides is shown as dimension "A" in FIG. 25.

COMPONENTS

STRAIGHT SECTIONS



DUCT LENGTH (PIC)

Duct sections are joined, using appropriate sealant, to make up desired length of run. These sections may be modified by use of nipples or couplings to accept auxiliary equipment such as temperature probes or smoke monitors. Consult factory or your local representative to obtain information regarding such modifications.

DUCT DRAIN (DR)

The duct drain is intended for use at the end of a horizontal run where access and drainage is needed (See FIG. 26). The drain coupling must be connected to a grease trap or approved container (supplied by others).

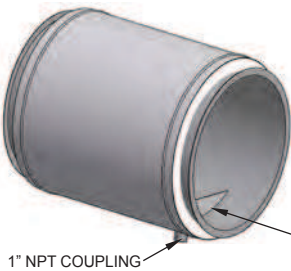

1" NPT COUPLING

GREASE DAM
(LOCATE DOWN SLOPE)

FIG. 26 - DUCT DRAIN TYPICAL LOCATION

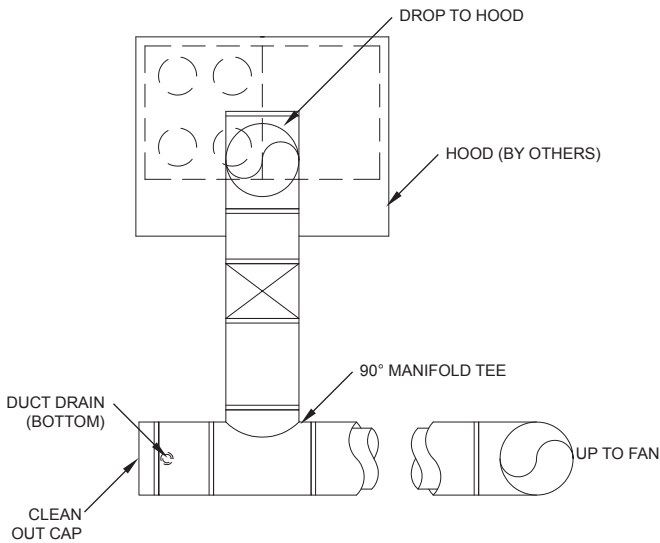

NOZZLE SECTION (NS)



Nozzle Sections are used when the duct is required to be equipped with a fire suppression system or wash down is desired. Nozzle Sections are equipped with a 1" (25) NPT coupling which is attached to inner wall and extends through the outer wall. Vertical nozzle sections can have the coupling located at the most convenient place (See FIG. 27). Horizontal oriented nozzle sections are to be installed so that the coupling is at or above the horizontal centerline of the duct.

FIG. 27 - DRAIN BUCKET AND NOZZLE SECTION TYPICAL LOCATIONS

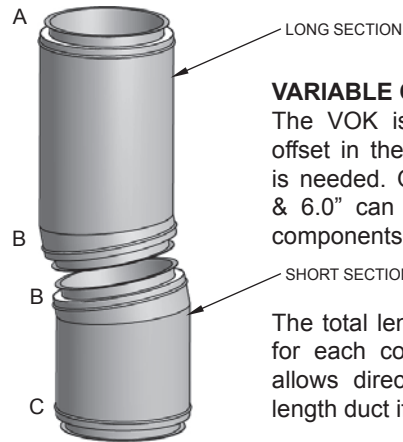
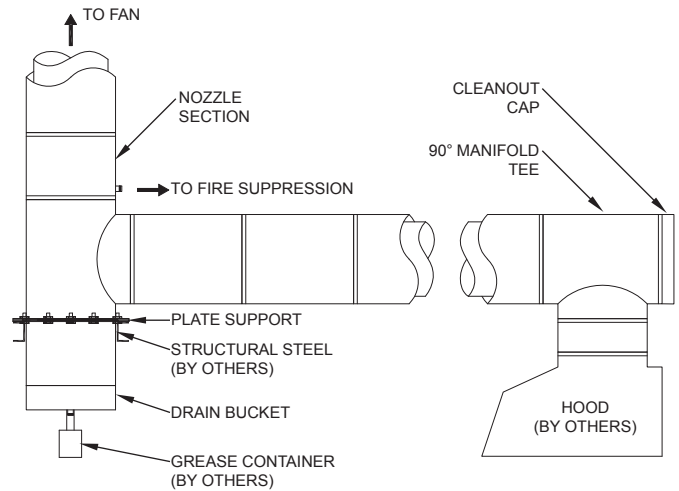

VARIABLE OFFSET KIT (VOK)

The VOK is used when a minimal offset in the vertical stack alignment is needed. Offsets of 1.5", 3.0", 4.5" & 6.0" can be obtained by rotating components as shown in FIG. 28.

The total length is approximately 42" for each configuration. This feature allows direct replacement of a 42" length duct if needed.

FIG. 28 - VOK CONFIGURATIONS

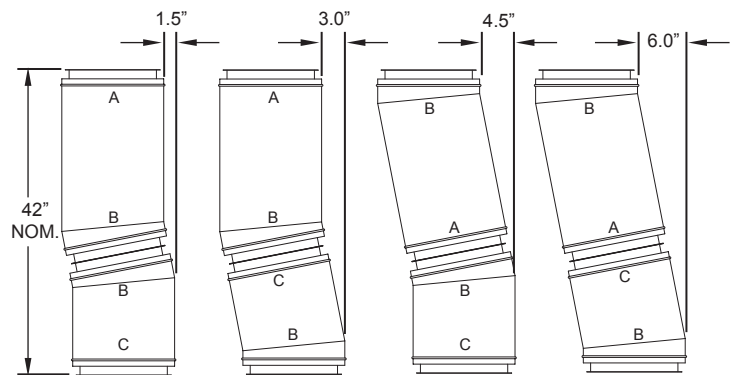

VARIABLE LENGTH (VL)

Variable Length is used to make up odd lengths of duct (See FIG. 29), but is not to be used for expansion compensation.

If flue is too long to fit into the adjacent section of duct without interfering with the flow path, it should be trimmed to the desired flange to flange length + 4" (102). Flange to flange length adjustment can range from 4" to 26".

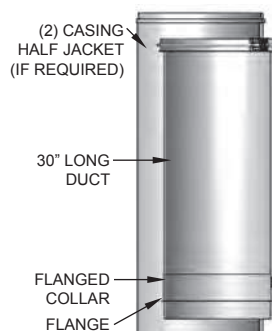
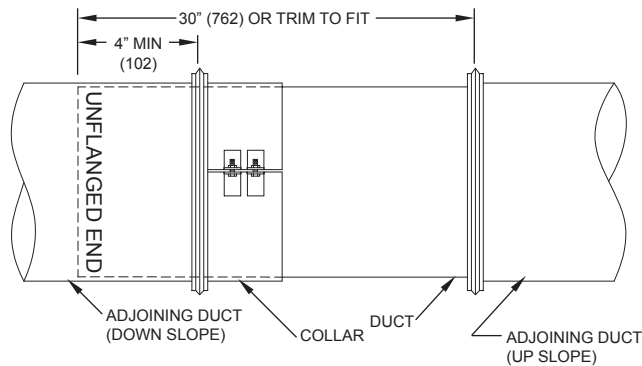

FIG. 29 - VARIABLE LENGTH FLUE ASSEMBLY



ADJUSTABLE LENGTH EXPANSION JOINT (AL)

Adjustable Length is used to compensate for thermal expansion and to make up odd lengths of duct (see FIG. 30). Sufficient installed length is to be allowed to compensate for abnormal, as well as normal, operating conditions. Adjustable Length cannot be used to correct misalignment or to compensate for lateral movement or vibration.

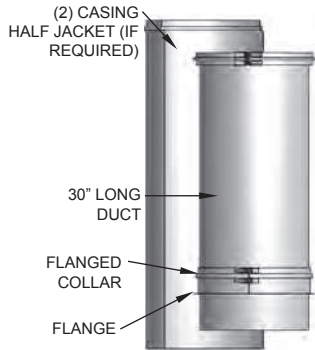
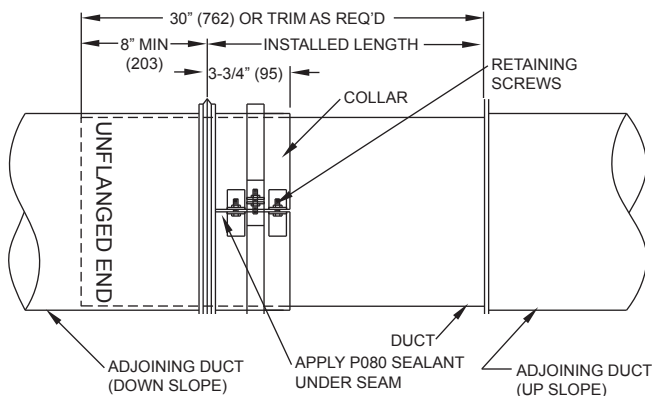
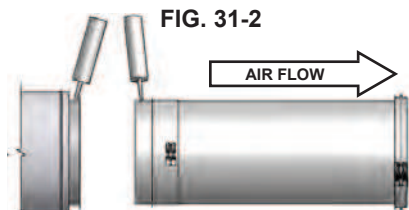

FIG. 30 - ADJUSTABLE LENGTH FLUE ASSEMBLY



VL AND AL JOINT INSTALLATION

1. Loosen draw screws at collar and slide collar toward flange end of duct. Do not remove collar from duct.
2. **(VL Only)** Apply a thin coat of sealant, about 1" (25) wide at the unflanged end of the VL joint where the joint slides into mating duct section. Press sealant into any gap between the VL joint and the mating joint section. Apply sealant to flange of mating duct (See FIG. 31-2)



3. **(AL Only)** Apply a continuous bead of sealant at the collar overlap seam (See FIG. 30).
4. Slide unflanged end of VL or AL joint into upstream piece of duct. Make up joint between duct and collar as outlined under JOINT ASSEMBLY on page 4. Firmly tighten retaining screws on collar to complete installation.

5. Put flanged end of the VL or AL joint to the downstream piece of duct and make up joint as outlined under JOINT ASSEMBLY on page 4.
6. Cut insulation to desired length and wrap inner duct ensuring that it is covered completely before attaching casing half jackets.
7. Wrap casing half jackets around joint with bead at the downstream end. Punched edge of one half should overlap unpunched edge of other half by approximately 3/4". Make sure the overlaps do not align with the draw screws of flange band (See FIG. 31-6).

NOTE: For horizontal installations, the seams must be located at the top and bottom of duct.

FIG. 31-6

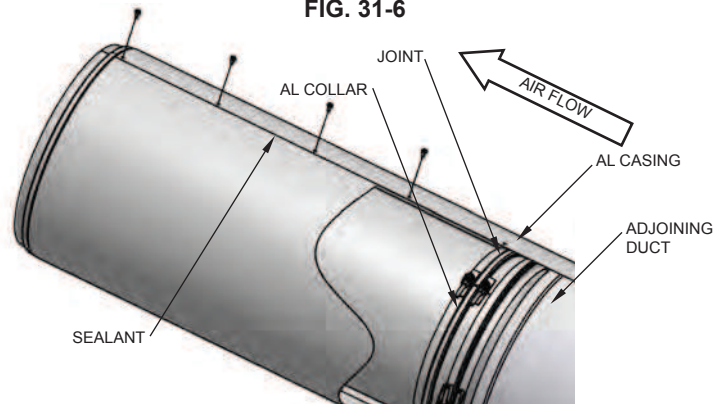

Coat the unpunched edge of each casing half jacket with P077 sealant to waterproof the casing. Install self-drilling screws (supplied with jacket) at punched holes through both layers of overlap as shown in FIG. 31-6. No screw should be installed in portion of jacket which overlaps the casing of an adjacent piece of duct.

WARNING: DO NOT USE ANY OTHER SCREWS TO ATTACH THE CASING JACKET. SUPPLIED SCREWS ARE THE CORRECT LENGTH TO AVOID PENETRATING THE INNER WALL OF DUCT.

IMPORTANT: IF AIR FLOW IS IN DIRECTION OF DOWNWARD SLOPE, REVERSE ORIENTATION OF VL & AL TO MATCH FIG. 29 AND FIG. 30.

Additional VL and AL Joint Install Notes:

1. It is recommended that the duct on both sides of the VL or AL joint is supported or guided to ensure that the VL or AL joint will not bind during operation. See Variable & Adjustable Length Support section on page 9 for typical support applications.
2. Installation of an AL joint adjacent to fittings, such as elbows, tees or wyes, is not recommended. However, if an AL or VL joint must be joined to one of these fittings, the **unflanged end** (See FIG. 29 & 30) of the tube should always point downward or towards downward slope.
3. AL joint must be installed with a flange to flange length of not more than 22" (558). The minimum length for installation must take into account the amount of expansion that may occur during operation. Minimum length is calculated as follows:

$$\text{Expansion} = \text{Length (feet)} / 100 \times \text{Temperature Rise (°F)} / 100$$

$$\text{Minimum Length} = \text{Expansion} + 6" (152\text{mm})$$

It is recommended that the temperature used in the above formula be at least 300°F higher than the expected normal operating temperature.

- If the inner tube is too long, it may be cut to length. Tube must be a minimum of 4" (102) for VL or 8" (203) for AL longer than flange-to-flange length. Prior to installation of cut duct, remove all burrs to ensure that interference does not occur.
- (AL Only)** Check gasket to ensure that it fits snugly without binding on inner duct. (See FIG. 32-5)

FIG. 32-5

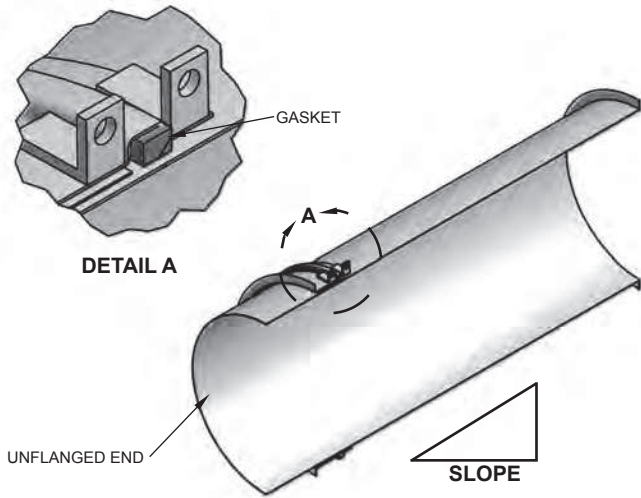

- Outer jacket must move during expansion or contraction. Ensure that no screws are located where the jacket overlaps the casing of the adjacent duct and that it is loose enough to move as needed. Alignment of the bead on jacket with the bead on the adjacent duct will ensure that the jacket stays in the proper location.
- VL and AL joints will not support any weight in the vertical position. It should not be used unless both ends of run, where a VL or AL is installed, are anchored as fixed points.
- FIG. 32-8 shows typical Adjustable Length installation.

FIG. 32-8

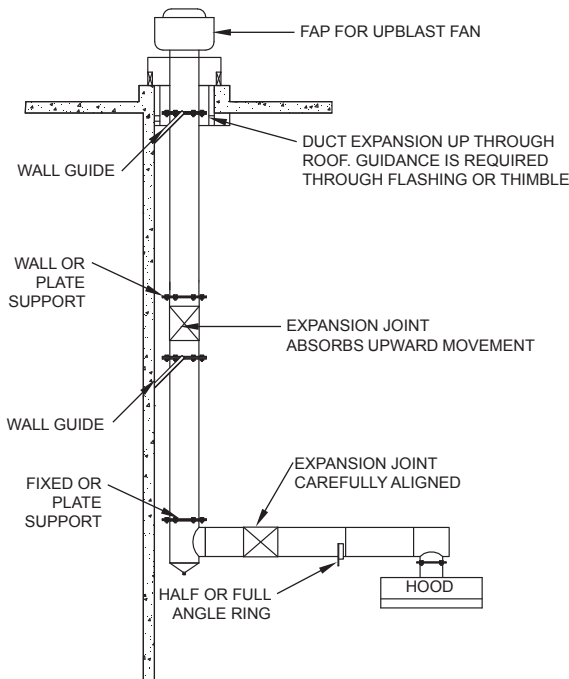

FITTINGS – ELBOWS, WYES, TEES, & TRANSITIONS

STANDARD 90° TEE (90MT)

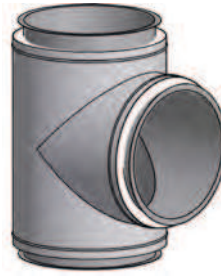

The 90° Manifold Tee may be used to connect horizontal to vertical when a cleanout access or drain is desired. If more than 1/4" (6) of thermal expansion is expected between the tee and the next fixed support point (the hood outlet, for example), the tee should be protected from bending moments by use of an Adjustable Length Expansion Joint. See page 17 for information on the Adjustable Length.

GREASE MANIFOLD TEE (GMT)



The Grease Manifold Tee is equipped with a 1 1/2" (38) high grease dam at the access port. The access port must be closed with a Cleanout Cap (TCN) or Toolless Access Panel (TAP).

The location of the access port in the Tee is dependent on the orientation of the Tee in the final installation. Access port location is coded as Position 1, 2, 3, 4, or 5 (See FIG. 33)

FIG. 33 - GMT ACCESS PORT LOCATIONS

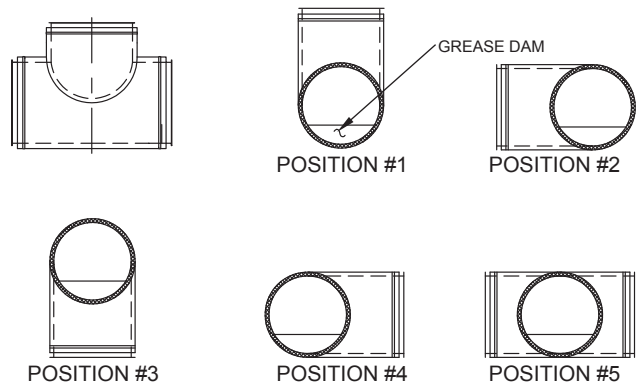

45° MANIFOLD TEE (45MT)



Isolate the 45° Manifold Tee from the effects of thermal expansion.

DOUBLE LATERAL (DL)



The Double Lateral is a manifold tee with two 45° entrances to trunk. The installation details are the same as a 45° Manifold Tee.

TEE CAPS

The unused port of a tee must be closed to prevent leakage of grease vapors/liquids. This can be accomplished using a Tee Cap, Cleanout Cap or Tool-Less Access Panel. The caps are equipped with closures, which serve the dual purpose of maintaining the double wall clearance to combustible and giving the cap a finished appearance.



1" NPT DRAIN WITH CAP

TEE CAP (TC)

A Tee Cap is used to close the Tee and drain grease when the Tee is installed at the base of a rise. The drain nipple must be connected to a suitable disposal point. The Tee Cap must be sealed at

the connection to the tee using the appropriate sealant for the application. This will assure that moisture will drain through the drain nipple, as intended.

CLEANOUT CAP (TCN)

The Clean Out Cap provides access for cleaning and inspection into the grease duct. It is recommended for use on Tees used for cleanout or access purposes only. When

using clean-outs, always seal the connection to prevent leaks and assure that the grease duct functions as intended. The TCN is installed as shown in FIG. 34.

1. Apply sealant to duct flange and Tee Cap Weldment. Then attach Tee Cap Weldment to Tee flange and secure with Flange Band.
2. Install insulation provided (if applicable).
3. Loosen the End Closure retaining screws and slide End Closure over Tee Cap Weldment. Align the End Closure groove over the duct casing bead and secure by tightening the retaining screws.

FIG. 34 - CLEAN OUT CAP (TCN) INSTALLATION

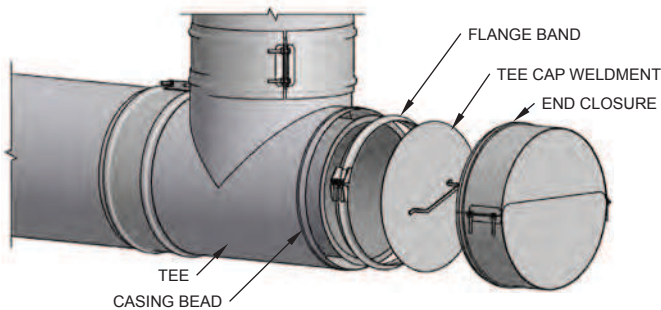

TOOL-LESS ACCESS PANEL (TAP)

Tool-less Access Panels are available in duct sizes from 6" (152) to 36" (914) diameter. The TAP is offered as an alternative to the TCN to allow

for complete access for inspection and cleaning without the use of tools. The TAP complies with requirements of NFPA 96 and the International Mechanical Code for accessibility. The TAP is designed to retrofit existing installations that use a TCN.

Installation of the TAP is as follows:

1. Attach TAP access cover base plate to Tee using flange band (See FIG. 35).
2. Connect access cover to base plate and secure with wing nuts. Gasket side of cover is to contact the access cover base plate.

FIG. 35 - TOOL-LESS ACCESS PANEL (TAP) INSTALLATION

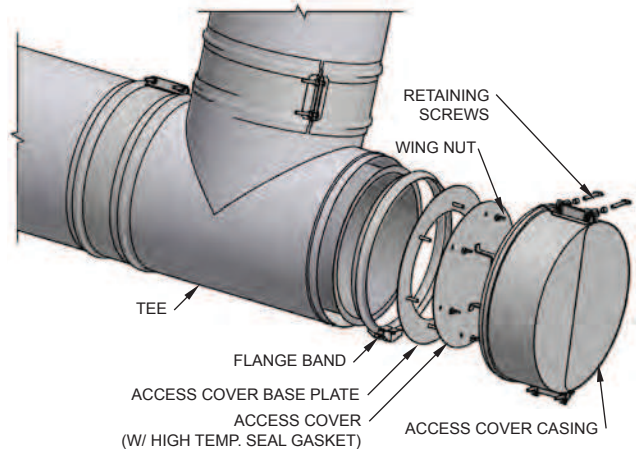

3. Install insulation around flange band and within Access Cover Casing.
4. Attach access cover casing on Tee making sure the Tee casing bead is aligned with the cover casing groove. Tighten retaining screws.

SIDEWALL TOOL-LESS ACCESS PANEL (STAP)

Sidewall Tool-less Access Panels are available in duct sizes from 10" (254) to 36" (914) diameter. The STAP is an alternative design for the TAP. It allows for complete access for inspection and cleaning



without tools. The STAP complies with requirements of the NFPA 96 for accessibility.

Installation of the STAP is as follows:

1. Duct joint assembly is the same as standard straight duct (See Page 2).
2. Connect access cover to duct and secure with wing nuts (See FIG. 36).
3. Insert insulation pillow.
4. Attach casing cover and secure with snap locks.

FIG. 36 - SIDEWALL TOOL-LESS ACCESS PANEL (STAP) INSTALLATION

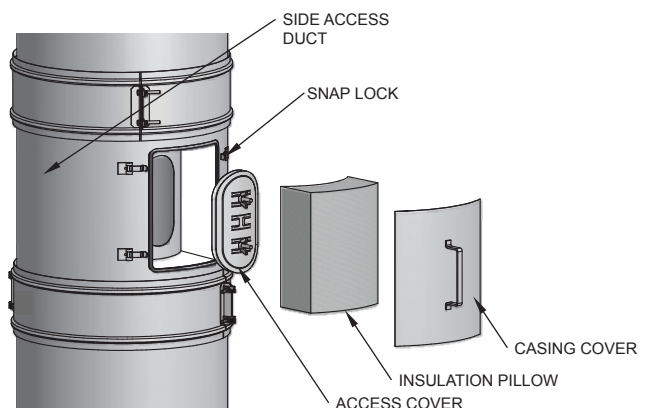

ELBOWS

Elbows are not designed to resist bending loads and must be protected by structural reinforcement as outlined under ELBOW SUPPORT on page 9 and 10. Custom elbows are available upon request. Consult factory for details.



15° ELBOW (15L)

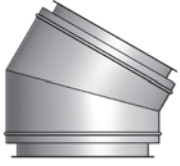

30° ELBOW (30L)



45° ELBOW (45L)

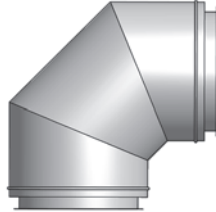

90° ELBOW (90L)



90° WYE (90Y)

The 90° WYE is useful when the vertical duct is located between two appliances and a low-loss junction is desired. The WYE fitting may be suspended by a Plate Support or Roof Support Assembly. Expansion joints should be used to protect the WYE from thermal expansion stresses.

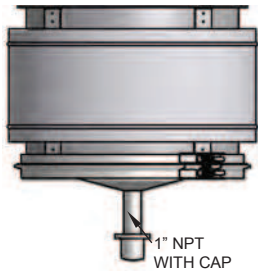

DRAIN BUCKET (DB)

Drain Bucket consists of a 9" (229) long duct section with an installed cap. It is intended for use as a drain point and access at the base of a duct riser (See FIG. 27). The drain nipple must be attached to a grease trap or approved container (supplied by others).

TAPERED INCREASER (TI)

Tapered Increases are used for a diameter change in duct systems. Use when there is a sufficient length of duct run available for the size change. The Tapered Increaser uses 5" (127) of length per incremental diameter change. The maximum length for a Tapered Increaser is 30" (762) or six duct sizes. A Tapered Increaser is considered to have the same load strength as a straight duct.

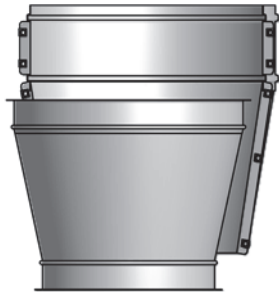

Increases are typically used to provide an increase in duct size, but they may be used to reduce the size of a run as well. **Extreme caution should be exercised in reducing duct size due to the resultant increases in duct resistance.**

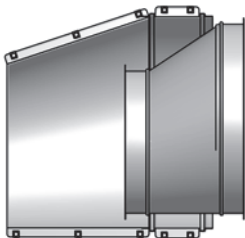

ECCENTRIC TAPERED INCREASER (ETI)

Eccentric Tapered Increaser is similar to the Tapered Increaser except the smaller diameter collar is offset from the larger diameter collar.

STEP INCREASER (SI)

Step Increases are used for a diameter change in duct systems. Use when length of duct run for the size change is restricted. The installed length of a step increaser is 3" (76). The step increaser is a non-structural part and must not be subjected to loading in either the axial or lateral directions.



Increases are typically used to provide an increase in duct size, but they may be used to reduce the size of a run as well. **Extreme caution should be exercised in reducing duct size because the resultant increases in duct resistance.**

ROUND HOOD COLLAR (RHC)

Round Hood Collar is used to connect the first duct section to hood. The collar is to be welded to the hood connection. Collar must be used with a Round Hood Connection Kit (RHCK) to complete installation.



ROUND HOOD CONNECTION KIT (RHCK)

Kit includes one 6" wide closure band, insulation (if required) and flange band.



HOOD CONNECTION - When a kitchen exhaust hood is equipped with a square or rectangular collar, a square to round adapter is needed to connect the round duct to the hood. The outside dimensions of the square end are slightly smaller than the hood collar. It will fit inside the collar and be connected by means of lap weld. Alternatively, the square end may be equipped with a flange to be used for a bolted or welded connection in accordance with NFPA 96.

SQUARE TO ROUND ADAPTER (STR)

Used to connect a round duct to a hood equipped with a square or rectangular collar. The STR square dimension is designed to fit inside of the hood collar. STR is connected to hood collar by means of a lap weld.



ECCENTRIC SQUARE TO ROUND ADAPTER (ESTR)

ESTR is similar to a STR except the round collar is offset from center of the square collar.

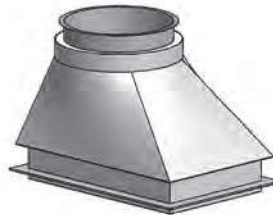

When ordering a square to round adapter for connection to kitchen exhaust hoods, the following information must be specified:

- The exact size of the square or rectangular end
- Any flanging requirements (typically flange is 1-1/2" wide)
- Diameter of the round end (i.e. size of G-Series Duct)
- Overall length - 18" standard.

NOTE: Many hood manufacturers have the capability to build the exhaust hood with a round flanged collar, which matches the flange on the duct. Others can install a round flanged collar supplied to them or can provide a hood without a collar for the outlet hole to be field cut. These alternatives are permissible to avoid the necessity of providing a square to round adapter.

DUCT TRANSITION - (IPIC Series 3G & 4G only) As a general rule, Model IPIC Series 3G & 4G grease duct systems are intended to be installed as complete systems without the use of other manufactured or generic components. However, Metal-Fab recognizes that in some instances due to space limitations at certain locations within a system the need to transition from IPIC G-Series to rectangular welded duct and back to IPIC G-Series may exist. See **FIG. 37-1 thru 37-4** for typical installations.

The square to round adapter is very useful for interconnecting round grease duct to rectangular welded duct where necessary due to space limitations or for breaching larger rectangular ducts used as a central shaft. In such cases, it is permissible to interconnect or transition parts from Metal-Fab IPIC Series 3G & 4G grease duct to a code compliant, rectangular welded steel duct system (by others) and back again. When such situations occur, Metal-Fab will fabricate and supply a fully welded round to rectangular transition that is code compliant single wall grease duct (fabricated of a

minimum 0.043" thick stainless steel) that is specifically designed to provide proper drain slope for the transition. These transitions provide direct connection to IPIC Series 3G & 4G duct at the round end and allow for a field welded connection to code complaint welded steel grease duct at the rectangular end.

To comply with national codes, these transitions are to be fully enclosed in same manner as the welded grease duct that it is connected to. Such enclosure systems may be either a field applied wrap system or a separate fire protective shaft enclosure with an appropriate fire resistance rating. When installed with IPIC Series 3G & 4G, the fire rated enclosure system must extend up to the adjacent G-Series duct section. The transition to flexible wrap enclosure is approved by Underwriters Laboratories provided the enclosure material is UL Classified per ASTM E2336, classified for use as a grease duct assembly per UL CAT. HNKT (See Batts and Blankets CAT. HNMF) or Intertek Design No. MFI/FRD 120-01 and is equal or greater than the fire rating of Series 4G.

FIG. 37-1 SQUARE TO ROUND TRANSITION FROM EXHAUST HOOD TO SERIES 3G & 4G GREASE DUCT

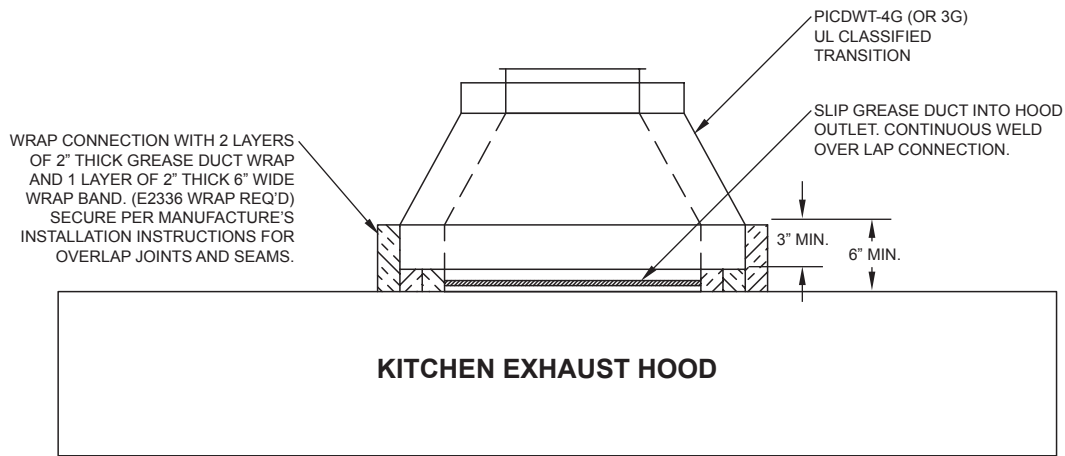

37-2 SERIES 3G & 4G TRANSITION TO FIRE RATED FLEXIBLE ENCLOSURE SYSTEM (Required For U.L. Classified Flexible Wrap Enclosure Systems)

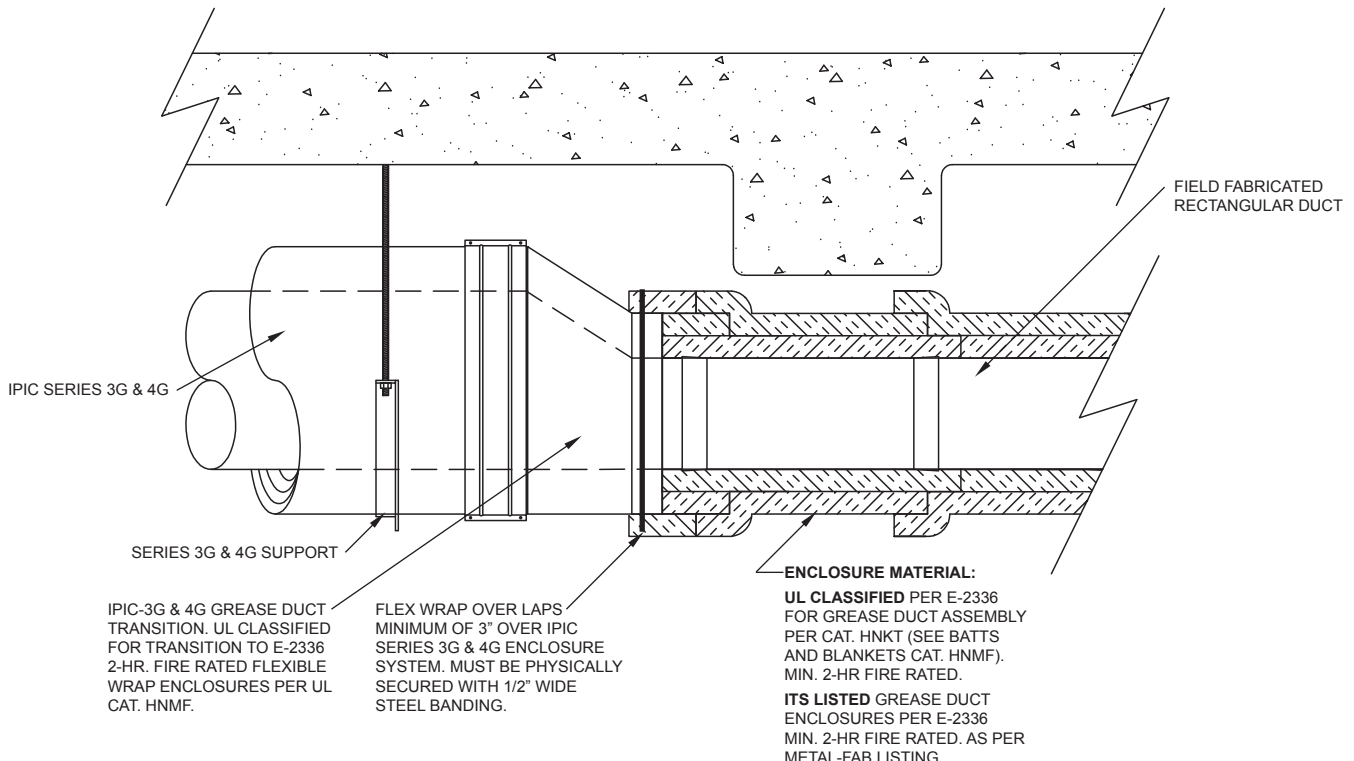

FIG. 37-3 TRANSITION SHOWN WITHOUT FIRE RATED FLEXIBLE ENCLOSURE SYSTEM INSTALLED (Series 4G ONLY)

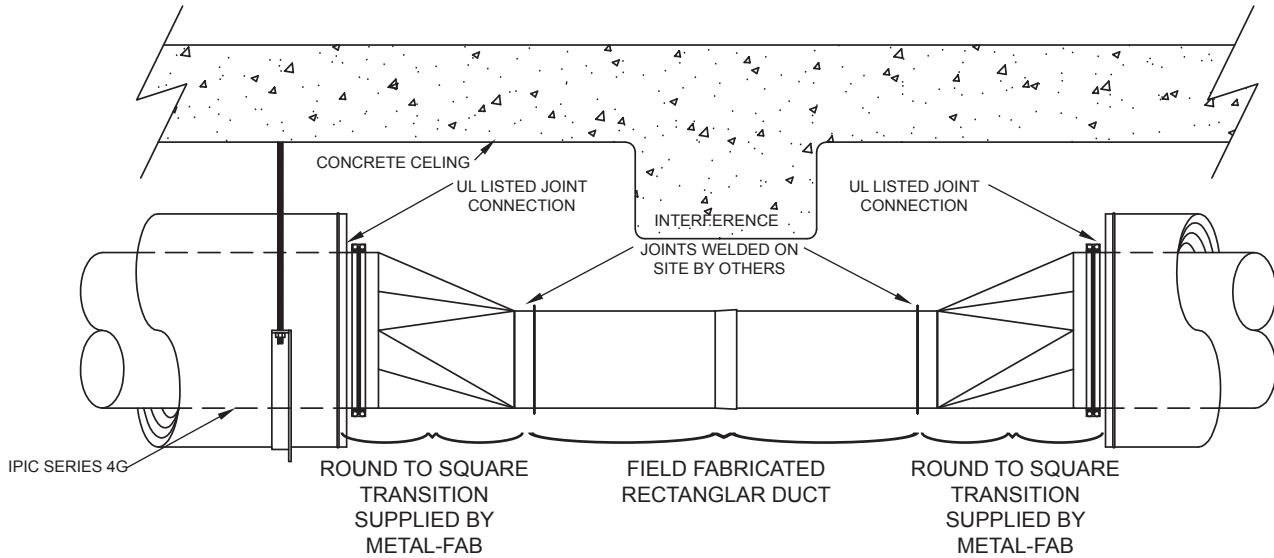
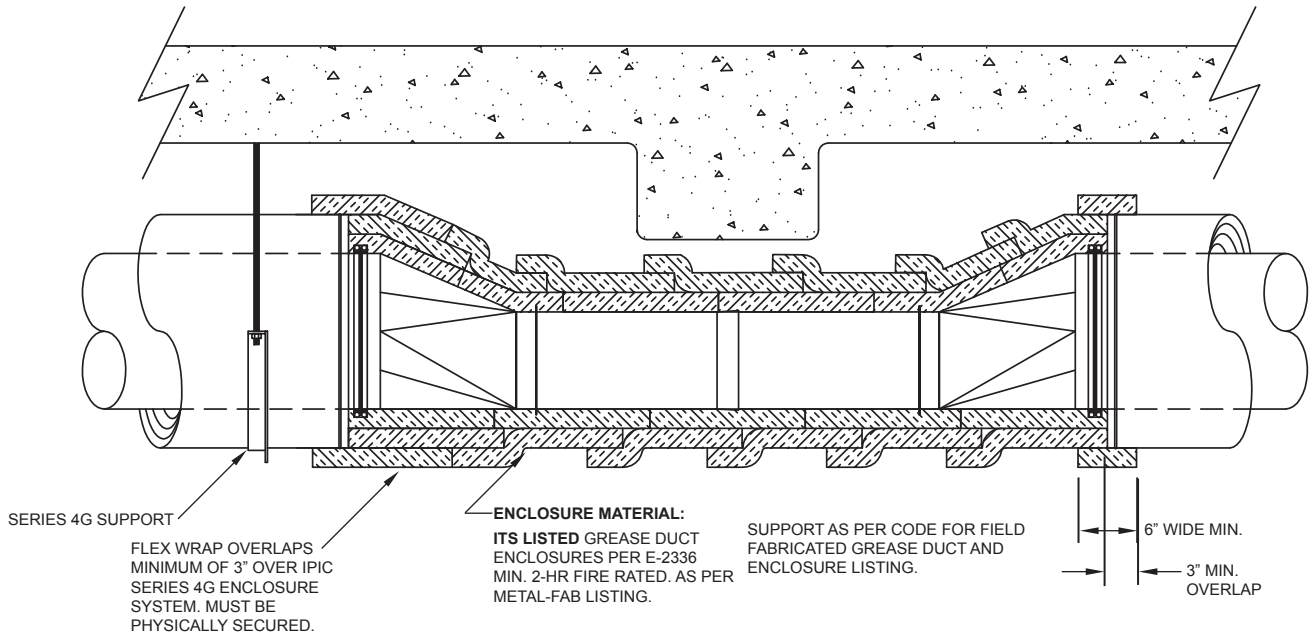

FIG 37-4 TRANSITION SHOWN WITH FIRE RATED FLEXIBLE ENCLOSURE SYSTEM INSTALLED (Series 4G ONLY)



SPRINKLER HEAD ACCESS PANEL (SHAP)

The SHAP is used to quickly install, remove or service a sprinkler head used for fire suppression in a kitchen exhaust duct (See FIG. 38). This device is intended for use where jurisdictions require additional fire suppression methods such as hard plumbed sprinkler heads installed per NFPA 13.

SHAP is retained with four (4) wing nuts and one (1) tamper proof TORX™ screw. Special TORX™ drive bits are provided by Metal-Fab to the local fire suppression inspectors in order to access the SHAP.

FIG. 38 - SPRINKLER HEAD ACCESS PANEL

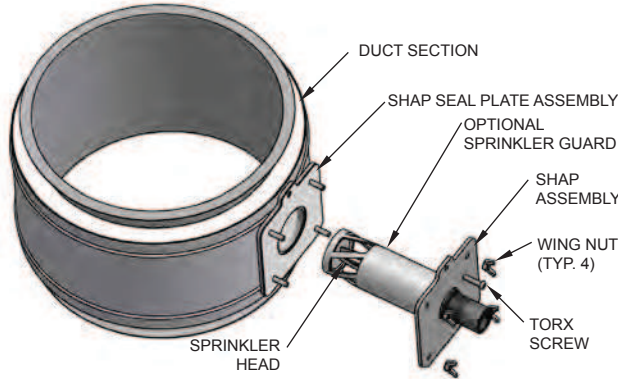

The SHAP is factory installed inside a duct section. A flexible water line connection, such as provided by Flexhead™ or other similar product, is required in order to provide access to the SHAP.

For horizontal ducts, the SHAP must be located above horizontal (vertical orientation preferred) to avoid risk of leakage during duct wash down cycle.

FAN ADAPTER PLATE (FAP)

The Fan Adapter Plate is designed to connect an upblast fan mounted on a roof curb. The plate is formed to provide a slope to allow grease deposits to flow back towards the duct.

When connected to an upblast fan (See FIG. 39), the plate mounts on top of the fan curb which supports the fan housing. The plate may be positioned off center within the curb provided that minimum clearance to combustibles is maintained. In the event that the plate is positioned off center, trim off excess plate material to allow fan placement. Secure the plate to the curb a minimum three (3) places per side with a minimum size #8 x 1-1/4" wood screws. The fan housing is set on top of the plate and sealed using P080 sealant or an approved gasket supplied by the fan manufacturer. Specify the pipe diameter and outside curb dimensions when ordering the Fan Adapter Plate.

The Fan Adapter Plate can be used as a vertical support. The maximum height of duct supported by the Fan Adapter Plate is shown in TABLE 10.

TABLE 10 - FAP MAXIMUM VERTICAL SUPPORT

DIAMETER	6" - 18"	20" - 26"	28" - 36"
PSW/PIC	20' (6.1m)	20' (6.1m)	15' (4.6m)
1G, 1GV, IPIC-1	20' (6.1m)	20' (6.1m)	15' (4.6m)
2G, 2GV, IPIC-2	20' (6.1m)	20' (6.1m)	15' (4.6m)
3G, 3GV, IPIC-3	20' (6.1m)	15' (4.6m)	10' (3.1m)
4G, 4GV, IPIC-4	20' (6.1m)	15' (4.6m)	10' (3.1m)

WARNING: DO NOT EXCEED THE MAXIMUM LOAD LIMIT OF THE ROOF CURB OR THE ROOF.

FIG. 39 - FAN ADAPTER PLATE

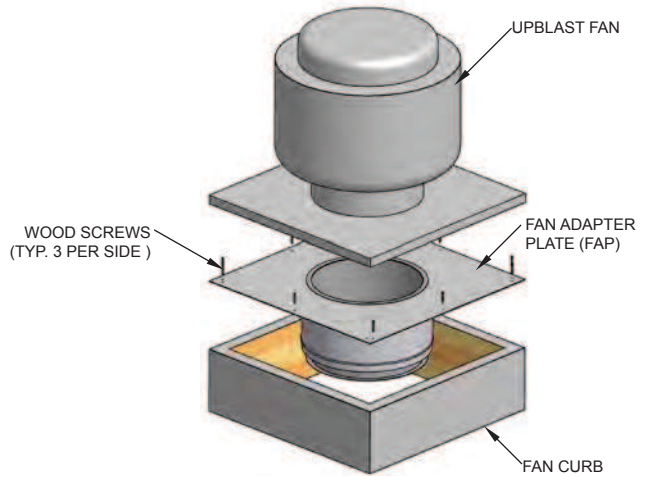

FAN / CURB TERMINATION (FCT)

The Fan / Curb termination is designed to be used in place of traditional curb / welded duct assembly. The Fan / Curb Termination is intended to be located and installed on a roof to serve as a fan curb with a self contained grease duct. The square termination is designed to directly connect to hinged type exhaust fans normally used for cooking fume extraction.

INSTALLATION: Prior to installing the Fan / Curb Termination, determine exact location that the grease duct system shall penetrate the roof. Cut a circular hole 3/4-inch larger than the diameter of the outer casing of the termination assembly.

Prior to installing the Fan / Curb Termination determine if adequate support by the roof assembly is available. In some applications, the Fan / Curb Termination will be used to support the total weight of the grease duct system and therefore additional cross supports for the roof may be required (See FIG. 40).

FIG. 40 - FAN / CURB TERMINATION

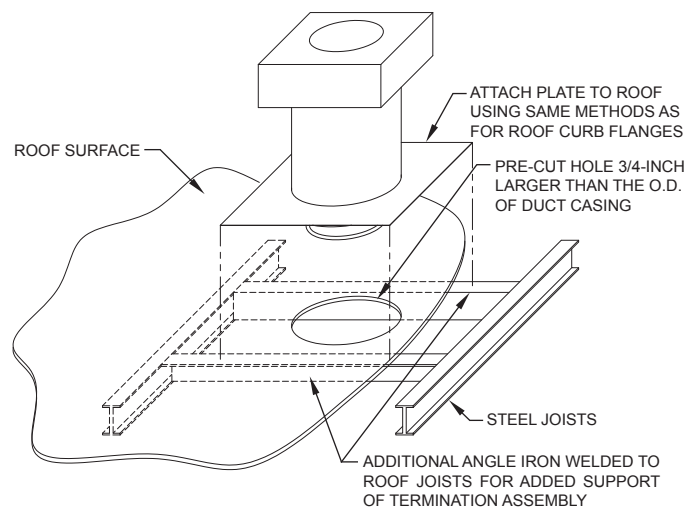

Once adequate support is available, install Fan / Curb Termination onto roof surface. The Fan / Curb Termination might require shimming in order to be level on the mounting surface. Attach Fan / Curb Termination plate to roof surface using similar methods used to secure roof curb to roof surface. Final sealing of roof surface should be applied after Fan / Curb Termination is installed or additional sealing of penetration will be required, as normally required for roof curb installations.

CHIMNEY (UL103) APPLICATIONS:

For kitchen exhaust applications that require chimney (UL103) listed systems, the following precautions must be followed if applicable to the engineered system:

- a. Do not place any type of insulation in the required clearance spaces surrounding the chimney;
- b. The framing of openings in ceilings and floors to provide firestopping in joist areas and the installation of firestop-spacer assemblies, shall be a minimum 2" clearance;
- c. The framing of openings in roofs to provide for support and attachment of roof assemblies, shall be a minimum 2" clearance;
- d. The chimney must be sized in accordance with the appliance manufacturer's instructions;
- e. It is recommended that exterior mounted chimneys below the roof line in geographical areas experiencing sustained low ambient temperatures are enclosed to help reduce or limit condensation, creosote buildup and poor draft;
- f. When offsets are permitted the maximum angle is not to exceed 30°.

OPERATING PRECAUTIONS (WOOD OVENS)

Creosote and Soot – Formation and Need for Removal

When wood is burned slowly, it produces tar and organic vapors which combines with expelled moisture to form creosote. The creosote vapors condense in the relatively cool grease duct of a slow burning fire. As a result, creosote residue accumulates on the duct. If ignited, this creosote makes an extremely hot fire. For this reason, the duct should be inspected at least once every two months to determine if a creosote or soot buildup has occurred. Consult local code and officials as they might require more frequent intervals. If creosote or soot has accumulated, it should be removed to reduce risk of fire.

A licensed or qualified grease duct cleaner should be contacted to clean the duct. Contact local building or fire officials about restrictions and installation inspection in your area. Adequate clearance is required around cleanouts to assure accessibility for removal of caps and products accumulated within the grease duct.

MAINTENANCE

Grease duct is required by NFPA 96 and many local building codes to be inspected and cleaned if necessary at specific intervals. Metal-Fab G-Series Grease Duct must be inspected and cleaned in accordance with local requirements. It requires no additional internal maintenance.

Metal-Fab recommends that grease containers connected to drainage points be emptied and washed out daily or more often, if necessary. If needed, the drain nipples should be checked and cleaned whenever the containers are emptied.

Where the duct is installed outside the building, the aluminized steel outer casing must be primed and painted. The paint surface should be maintained regularly to prevent possible deterioration of the casing surface. The use of stainless steel outer casing negates the need for painting.

NOTE: When solid fuel fired cooking appliances are vented with Models G-Series Grease Duct, creosote and grease may build up on the inner duct (flue) wall. This mixture can result in an unusually severe duct fire. To minimize fire hazard, the duct should be inspected weekly and any residue removed by cleaning. Additional requirements for solid fuel fired cooking appliances are outlined in NFPA 96.



P.O. Box 1138 • WICHITA, KANSAS 67201
PHONE: 316-943-2351 • 800-835-2830
FAX (316) 943-2717
www.metal-fabinc.com • www.greaseduct.com
info@metal-fabinc.com